

Wyong Rugby League Coaching Manual



WYONG ROOS
JUNIORS

Kids **2** Wyong Roos

Index

Chapters 1- 20

- 1) Coaching Contacts**
- 2) Code Of Conduct**
- 3) Safe Play Code**
- 4) Risk Management**
- 5) Ground Locations**
- 6) Using Morry Breen Complex**
- 7) Attendance Sheets**
- 8) Session Plan**
- 9) Pre game/Game stats sheet**
- 10) Development Programs**
- 11) 5-7 yrs**
- 12) 8-9 yrs**
- 13) 10-12 yrs**
- 14) 13-16 yrs**
- 15) Function of a drill**
- 16) Suggested Option Plays**
- 17) Nutrition & Recovery**
- 18) Scrums**
- 19) Drills & Games**
- 20) Catch & Pass Drills**

COACHING CONTACTS

Wyong Coaching Contacts

Matt Lavin- Development Officer

0414012437

Ian Naden- International Coaching Coordinator

0450752920

Shawn Chapman- Mod Coaching Coordinator

0418247251

Peter Stephen- Mini Coaching Coordinator

0423233250

CODE OF CONDUCT



NATIONAL CODE OF CONDUCT

(2008 Version)



NATIONAL CODE OF CONDUCT

Introduction

The purpose of this Code of Conduct is to provide all participants in Rugby League with some simple rules concerning the standards of behaviour that are expected.

I commend ARL Development for their efforts in producing this National Code of Conduct. It is another milestone in the continuing development of our great game.

I strongly recommend that everyone connected with Rugby League adopts these rules so that players, coaches, officials, parents and spectators can attend matches secure in the knowledge that it will be a safe and enjoyable sporting experience.

Regards,



Colin Love
Chairman, Australian Rugby League

General Principles

Participants in the game of Rugby League include players, parents, spectators, coaches, referees and officials. Every participant should:

- Discourage all instances of unsportsmanlike behaviour, foul or illegal play, or acts of violence, both on and off the field.
- Respect the rights, dignity and worth of every person regardless of their gender, ability/disability, sexual orientation, cultural background or religion.
- Condemn the use of recreational and performance-enhancing drugs and doping practices; their use endangers the health of players and is contrary to the concept of fair play.

Important – every person who attends a Rugby League match does so with the permission and license of the home club and/or league. Breaches of this Code of Conduct may result in penalties up to and including a fine, loss of team match points and suspension.

CODE OF CONDUCT – PLAYER

- Be a good sport. Respect all good play whether from your team or the opposition and shake hands with and thank the opposition players and officials after the game – win, lose or draw.
- Participate for your own enjoyment and benefit.
- Always respect the referee's decision.
- Never become involved in acts of foul play.
- Honour both the spirit and letter of the competition rules and live up to the highest ideals of ethics and sportsmanship; avoid gamesmanship and respect the traditions of the game.
- Never engage in disrespectful conduct of any sort including profanity, sledging, obscene gestures, offensive remarks, trash-talking, taunting or other actions that are demeaning to other players, officials or supporters.
- Care for and respect the facilities and equipment made available to you during training and competition.
- Safeguard your health; don't use any illegal or unhealthy substances.
- Recognize that many officials, coaches and referees are volunteers who give up their time to provide their services. Treat them with the utmost respect.
- Do not bet or otherwise financially speculate, directly or indirectly, on the outcome or any other aspect of a Rugby League match or competition in which you are involved.

Endorsement

Whether you play in the local U7's or for Australia, there are certain standards that you have to live up to.

Rugby League is one of the world's great games and if every player remembers, and practises, these few simple rules, the game will continue to prosper.

I fully endorse the player's section of this Code of Conduct.

Best wishes,

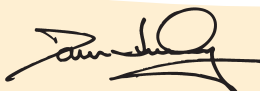

Darren Lockyer

Player - Brisbane Broncos, Queensland & Australia



CODE OF CONDUCT – COACH

- Actively discourage foul play and/or unsportsmanlike behaviour by players.
- Seek to maximise the participation and enjoyment for all players regardless of ability; avoid the tendency to over-use a talented player; treat all players as equals, regardless of their talent.
- Show concern and caution towards all sick and injured players. Follow the advice of a physician and/or sports trainer to the letter when determining when an injured player is ready to recommence training or playing.
- Teach players that an honest effort and competing to the best of their ability is as important as victory.
- Maintain appropriate, professional relationships with players at all times.
- Maintain a thorough knowledge of the rules of the game and keep abreast of current coaching methods; maintain or improve your current accreditation level.
- Always consider the health, safety and welfare of the players.
- Teach young players to realise that there is a big gap between their play and the professional game; do not coach them as if they are professionals.
- Ensure that your coaching reflects the level of the competition being played; do not be a “winner-at-all-costs” coach.
- As coach, conduct yourself at all times in a manner, and in all situations, that shows leadership, respect for the game of Rugby League and respect for all those that are involved in the game – the players, officials, the fans, the parents, the referees and the media.

Endorsement

As a coach, you have a special responsibility to ensure that, through your words and actions, you strive to build the character of your players, as well as their skills.

You also have to maintain and nurture the traditions and integrity of the game.

Be gracious in victory and accept defeat with dignity and remember, constantly promote sportsmanship over gamesmanship.

Good luck.



Ricky Stuart.

Ricky Stuart

Coach - Cronulla Sharks and Australia



CODE OF CONDUCT – REFEREE/TOUCH JUDGE/OFFICIAL

- Be impartial! Also, be consistent, objective and courteous.
- Place the safety and welfare of the players above all else; be alert to minimise dangerous physical play, fair or foul, especially in junior matches.
- Accept responsibility for all actions taken.
- Avoid any form of verbal contact with coaches, team officials, parents and spectators during play.
- Avoid any situation which may lead to a conflict of interest, both on and off the field.
- Maintain an appropriate level of fitness for the standard of game at which you are officiating.
- Condemn all and every instance of unsportsmanlike, foul or unfair play.
- Set a good example by the way you dress, speak and act towards players, coaches, officials, parents and spectators.
- Show concern and caution towards sick and injured players.
- Officiate to the age and/or experience of the players.



Endorsement

As a referee, you are an integral part of the game and you can help each player enjoy the game by demonstrating a positive attitude, by promoting good sporting behaviour, by being consistent and by communicating in a fair and honest manner.

Try to clearly express your decisions to the players in a way that can be seen and understood.

Keep up to date with the latest trends in officiating and remember, there is no substitute for a thorough knowledge of the Laws of the Game and your own integrity.

Bill Harrigan

*Bill Harrigan
Former NRL, Origin & Test Referee*

***Referees are the key to the successful application
of the Safeplay Code in Junior Rugby League.***

CODE OF CONDUCT – SPECTATOR/PARENT

- Condemn all violent or illegal acts, whether they are by players, coaches, officials, parents or spectators.
- Respect the referee's decisions – don't complain or argue about calls or decisions during or after a game.
- Behave! Unsportsmanlike language, harassment or aggressive behaviour will not be tolerated.
- Encourage players to play by the rules and to respect opposition players and officials.
- Never ridicule or scorn a player for making a mistake – respect their efforts.
- Understand that sport is part of a total life experience, and the benefits of involvement go far beyond the final score of a game.
- Participate in positive cheering that encourages the players in the team you are supporting; do not engage in any cheering that taunts or intimidates opponents, their fans or officials.
- Remember that children participate in Rugby League for their own enjoyment, not yours!
- At all times, follow the directions of the Ground Manager and/or other match day staff.
- Never arrive at a Junior League game under the influence of alcohol, never bring alcohol to a Junior League game and only drink alcohol, if it is available, in a responsible manner in the designated licensed area.

Endorsement

I've always loved Rugby League - going to the games and supporting my favourite teams. But I don't love it when fans get unruly or cause trouble on the sidelines.

As a spectator, be sure to do the right thing. Enjoy the game and let the players know that win or lose, you support their efforts.

As a parent, lead by example, promote good sportsmanship and be a positive role model for your children.

I fully support this Code of Conduct.



Layne Beachley

Layne Beachley

Rugby League fan and seven-time ASP World Surfing Champion



Children learn best by example.

CODE OF CONDUCT – PENALTIES

Note – Clubs are responsible for the conduct of their players, parents/carers of players, coaches, officials and spectators.

1. No person/s attending a match shall:
 - a. Use offensive or obscene language to any player, coach, referee, touch judge, official or other spectator;
 - b. Enter the Field of Play during the course of a match without the prior approval of the Ground Manager appointed by the home club and/or league;
 - c. Dispute the decision of a referee or touch judge either during or after a match;
 - d. Assault or act with aggression to any person/s;
 - e. Behave in a way contrary to this Code of Conduct and/or the spirit of the game;
 - f. Behave in a way which disturbs the enjoyment of the match by any other person/s, or brings discredit to the home club and/or league;
 - g. Act in such a way as to exhibit racial intolerance, by language or other conduct, to any other person/s;
 - h. Refuse to accept the reasonable direction of the Ground Manager, official of the home club and/or league, or official of the team/club which that person/s is supporting.
2. Any person/s contravening **Rule 1** may be reported by the Ground Manager to the Team Manager or other official of the team which that person/s is supporting. Where a team does not have a Team Manager present, a request or direction from the Ground Manager to any official of the team or the team's club shall be regarded as a direction to the Team Manager for the purposes of this Code.
3. The Ground Manager and/or Team Manager must advise the offending person/s of the relevant breach of the Code. The Ground Manager must note the details of their report to the Team Manager on the reverse of the team sheet.
4. In the event that the inappropriate conduct continues, the Ground Manager and/or Team Manager may request the offender/s to immediately leave the ground. This should also be noted on the team sheet.
5. In the event the person/s refuses to obey the direction of the Ground Manager and/or Team Manager, the Ground Manager may direct the referee to terminate the match. In the event that the match is so terminated, the club's and/or league's committee may, at its absolute discretion award the competition points to the non-offending team, or declare that neither side shall be awarded competition points for that match.
6. Clubs which do not exercise control over their players, parents/carers of players, coaches, officials or spectators may be called upon by the league to accept responsibility for their actions and the following penalties may apply (in addition to penalties which may be imposed by the league's judiciary):
 - **FIRST OFFENCE**
A fine not exceeding \$500, and/or loss of competition points, and/or suspension of the player from playing, and/or suspension of the offender/s from attending future matches.
 - **SECOND OFFENCE**
Suspension of the player, and/or team and/or club from the competition on a temporary basis.
 - **THIRD OFFENCE**
Suspension of the player and/or team and/or club either for the remainder of the season, or permanently.

Breaches of this Code of Conduct may cause a match to be stopped!

NATIONAL CODE OF CONDUCT



ARL Development

(ABN 73 089 809 745)

5th Floor, 165 Phillip Street, Sydney NSW 2000

Tel: (02) 9223 6586, Fax (02) 9221 9333

Web: www.arldevelopment.com.au



Australian Government
Australian Sports Commission

SAFE PLAY CODE



NATIONAL SAFEPLAY CODE

(2010 Version)

(FOR PLAYERS AGED 15 YEARS AND UNDER)



INTRODUCTION

The Safeplay Code was developed to emphasise safety and good conduct within the game of Rugby League by creating the best possible on-field environment and actively controlling undesirable actions. It applies to all players up to and including the Under 15 years age group.

1. TACKLE ZONE

The Code: TACKLES ABOVE THE ARMPITS ARE NOT PERMITTED

Application: (a) When a ball-carrier is running with an upright posture, any tackle in which the defender's arm(s) makes contact above an armpit constitutes an infringement.
(b) It is an infringement for a defender/tackler to set upon the head or neck region of a ball-carrier.
(c) A defender, in front of a ball-carrier who is diving or running with a "stooped" posture, is permitted to come in contact with the ball-carrier's shoulder provided the defender's arm(s) extends down the shoulder and trunk, i.e. underneath the ball-carrier.

Reference: Law Book - Section 15, Law 1 (b), Page 38

2. DANGEROUS TACKLES

The Code: (2.1) THE TACKLER'S LEGS CANNOT BE USED TO TRIP IN A THROW.

Application: The use of the legs in a tackle is not permissible. Using the legs (even if the defender has a hand hold on the ball-carrier) to trip or throw constitutes an infringement.

Reference: Law Book - Section 15, Note to Law 1 (a), Page 38

The Code: (2.2) ADOPTING A CROTCH HOLD IS MISCONDUCT

Application: Adopting a crotch hold i.e. by placing either a hand or arm in the crotch region is an infringement.

Reference: Law Book - Section 15, Law 1 (d), Page 38

The Code: (2.3) NO VERTICAL LIFT IN A TACKLE IS PERMITTED

Application: Vertical lifting in a tackle is an infringement.

No defender(s), during the course of a tackle, are permitted to vertically lift the ball-carrier. If the possibility of a vertical lift occurs, i.e. one or both feet of the ball-carrier have been lifted off the ground, the referee must immediately blow the whistle to prevent the tackle from continuing. (This is not to be confused with a tackle that, in the same motion, "knocks" a player off his feet).

The Code: (2.4) A BALL-CARRIER CANNOT BE LIFTED AND DRIVEN

Application: A tackle that results in the ball-carrier being lifted and remaining off the ground while the tackler takes two (2) or more steps to drive the player (in any direction and while the ball-carrier's feet are off the ground) is an infringement.

Reference: Law Book - Section 15, Law 1 (d), Notes 1 (d), Page 38

The Code: (2.5) THE ADDITIONAL FOLLOWING ACTION(S) BY A TACKLER WILL ALSO INCUR AN IMMEDIATE PENALTY

Application: Whilst a player, in possession, is moving, it is an infringement for a defender to lift the trailing foot of the ball-carrier from behind. (Again, this is not to be confused with a tackle that in the same motion, "knocks" a player off his feet).

The Code: (2.6) A DEFENDER CANNOT "PUSH" THE BALL-CARRIER TO EFFECT/COMPLETE A TACKLE

Application: A defender who pushes the ball-carrier to effect/complete a tackle is guilty of an infringement.

3. SHOULDER CHARGE

The Code: A DEFENDER CANNOT "SHOULDER CHARGE" A BALL-CARRIER TO AFFECT A TACKLE.

Application: A defender who runs at a ball-carrier and, without attempting to tackle, grab or hold the ball-carrier, charges to make contact with the shoulder or with the upper arm (tucked into the side) is guilty of an infringement.

Reference: Law Book - Section 15, considered "Misconduct" or "Dangerous Play"

4. VICIOUS PALM

The Code: AN ATTACKING PLAYER CANNOT "THRUST" OUT AN ARM TO CONTACT THE DEFENDER ABOVE THE SHOULDER

Application: Any attacking player who violently punches or thrusts out an arm or uses an outstretched stiff arm so that the hand or fist contacts the neck, face or head of a defender commits an infringement. (This section does not state that a player cannot legitimately 'palm' the head, neck or face).

Reference: Law Book - Section 15, Law 1 (a), Page 38

5. SLINGING

The Code: THE USE OF THE BALL-CARRIER'S ARM, OR JERSEY TO SLING OR SWING A PLAYER IS PROHIBITED

Application: A defender who uses the arm or jersey of the ball-carrier to sling or swing the player in a tackle commits an infringement.

Reference: Law Book - Section 11, Note to Law 1. Page 23

6. SANDBAGGING (FLOPPING)

The Code: A DEFENDER CANNOT DROP OR FALL ON A PRONE PLAYER.

Application: It is an infringement for a defender to drop, dive or fall on a player in possession of the ball who is prone or stationary on the ground and not attempting to play-on. (A simple hand-on completes the tackle).

Reference: Law Book - Section 15, Law 1 (e) & (i), Page 38

7. SURRENDER (IN THE TACKLE)

The Code: BALL-CARRIERS MAY SURRENDER IN THE TACKLE. WHEN SMALL AND/OR INEXPERIENCED PLAYERS ARE INVOLVED IN A "SURRENDER", DEFENDERS MUST NOT COMPLETE THE TACKLE

Application: This rule is designed to protect beginners and small players by minimising risk and eliminating excessively robust play. The referee, NOT the player, calls 'held'. Players who are at an obvious disadvantage because of low levels of experience, are of small stature or show a lack of skill are to be protected when in possession of the ball and being tackled. Halt to play is to be called (BY THE REFEREE) when these players submit to the tackle or are held, subdued or their progress is halted by bigger or more experienced players. Failure by a tackler to respond to the referee's call is an infringement.

Reference: Law Book - Section 11, Law 2 (c), Page 23, Note to 2 (c), Page 24

8. VERBAL ABUSE / FOUL LANGUAGE

The Code: THE USE OF OBSCENE EXPLETIVES, THREATENING OR DENIGRATING WORDS IS NOT PERMITTED

Application: Verbal abuse, obscene language and sledging, including comments or words that threaten or denigrate an opponent, referee or supporter is an infringement. (If the individual cannot be identified, the team should be cautioned through the captain).

Reference: Law Book - Section 15, Law 1 (f), Page 38

9. SCRUMS

The Code: PUSHING OR PULLING IN, OR ROTATING A SCRUM IS NOT PERMITTED.

Application: All scrums are to be de-powered. Scrums will form as per the following instruction: FORM, ENGAGE & HOLD. A team that deliberately pushes or pulls in, or rotates a scrum is guilty of an infringement. Once the ball has been fed into the scrum, hookers only may strike for the ball. Second row players can lift a foot to rake the ball out of the scrum, but cannot step forward over the ball to cause the ball to come out of the scrum.

Reference: Law Book - Section 12, Law 4, Page 30

It should be noted that every penalty under the Safeplay Code should be accompanied by a caution and instruction to the player responsible for the infringement.

IMPORTANT NOTE

IT IS MANDATORY THAT A PENALTY KICK FOLLOW ANY ACT THAT TRANSGRESSES THE SAFEPLAY CODE. ACTION, IN ADDITION TO A PENALTY FOR A BREACH (i.e. SIN BIN OR REPLACEMENT IN MINI/MOD) IS DISMISSAL AT THE DISCRETION OF THE REFEREE. (Refer International Laws, Section 13, 1 (a) and Section 15 - Players Misconduct)

ADVANTAGE PLAY & THE SAFEPLAY CODE

A penalty kick must follow any infringement.

1. IF NO ADVANTAGE OCCURS, the penalty is to be awarded immediately.
2. IF AN ADVANTAGE OCCURS, the penalty is to be awarded either at the breakdown in play immediately after the misconduct occurred, (unless a try is imminent) or where the act of misconduct occurred, whichever is to the greater advantage to the non-offending team.
3. WHEN A TRY HAS BEEN SCORED in the same play in which the act of misconduct occurred or in the immediate play thereafter (the imminent factor), the penalty kick, additional to the conversion, will be awarded in front of the goal posts. A kick at goal must be taken from the penalty kick (place or drop) and play restarted from the centre on the half-way line irrespective of the outcome of the kick.

Acknowledgement - The original Safeplay Code was written by Graham Chaffey, NSW Rugby League.



Australian Government
Australian Sports Commission



ARL Development

(ABN 73 089 809 745)

5th Floor, 165 Phillip Street, Sydney NSW 2000

Tel: (02) 9223 6586, Fax (02) 9221 9333

Web: www.arldevelopment.com.au



RISK MANAGEMENT



Chapter 4



1. Provide a safe environment

- Detect and foresee any dangerous situations
 - Inspection of facilities
 - Inspection of equipment
 - Removal of dangerous items from playing arena
 - Use of protective equipment e.g. goal post padding
 - Spectators well away from playing area
- Environmental conditions
 - Heat, humidity, fluid replacement
 - Hypothermia

2. Sound planning

- Documented plans of action for supervising activities and emergency situations
- Accurate records of practice
- Plans to prevent injuries
 - Warm up
 - Stretching
 - Cool Down
 - Obeying the rules

3. Adequate supervision

- General supervision – e.g. supervising general use of the arena
- Specific supervision – e.g. coach in a high risk activity such as tackling practice
- Transitional supervision – i.e. a mix of the two

4. Proper instruction

- Proper instruction (including demonstration) on techniques and tactics of Rugby League
- Teach progressively an activity which requires an increase in skill level, strength or conditioning

5. Anticipate danger

- Be mindful of anticipating reasonably foreseeable dangers
- Prevention is the priority to treatment

6. Warning of inherent dangers

- The players must know, understand and appreciate the risks involved when training and/or competing



7. Evaluation of players for limitations

- Injuries or illness will limit the players ability to participate
- Obtain doctors/first aid officers advice to clear players after injury or illness

Note: Emphasis on players to advise coaches/officials of injuries

8. Proper classification of players

- Criteria to be considered in classifying players
 - Skill level
 - Age
 - Maturity
 - Size: Weight / height
 - Experience
 - Gender

9. Teach the Laws and rules of Rugby League

- Rules relating to safety in particular
- All players should play within the Laws of Rugby League

10. Enforce the Laws of Rugby League to: -

- Control and supervise the game
- Control players

11. Control violent actions

- Inform that actions on-field may give rise to actions off-field (i.e. criminal charges/civil actions)

12. Discrimination and harassment

- Discourage any acts of discrimination and/or harassment

13. Sexual molestation

- Ensure that care is taken so there can be no molestation of young players
 - Child Protection legislation
 - Supervision

14. Selection policy

- Ensure that players are aware of selection criteria
- Train players with regard to them developing in areas appropriate to the selection criteria

Community Football Department, ARL Development

Program proudly sponsored by OAMPS



15. General

- Keep up to date with current practices in coaching and officiating
- Ensure counselling and information is available on the dangers of drug use (performance enhancing and recreational)
- Moral obligations – respect players – set the right example

16. Appropriate First Aid

- Knowledge of first aid skills and procedures
 - Basic certification in first aid care and CPR as a minimum
- Duties in providing first aid care: -
 - Protection from further harm
 - Maintaining or restoring life
 - Comforting and reassuring the injured athlete
 - Assessing and managing any injury
 - Activating emergence response plans where necessary

First Aid Basics

• DRABC

- Danger: check for danger
- Response: look for response from injured player. If no response: -
- Airways: with player on their side, open and clear airways
- Breathing: check for breathing
- Circulation: check for pulse

If a response, proceed to T.O.T.A.P.S. (refer below)

• When an injury occurs, remember T.O.T.A.P.S.

- Talk to the injured player
- Observe the injured player
- Touch the injured area
- Active movement
- Passive movement
- Stand / Skills
 - o 3 options
 - o Severe: get help
 - o Less severe: "R.I.C.E.R." regime (refer below)
 - o Minor injury: play on

• Soft tissue injury management – R.I.C.E.R. regime

- Rest: cease activity
- Ice: apply for 20 minutes every 2 hours for 24 to 72 hours (depending on severity of injury)
- Compression: firmly apply a wide compression bandage
- Elevation: raise injured area above heart level
- Refer: refer to a qualified professional e.g. doctor, physiotherapist



- **Soft tissue injury management continued**
 - Avoid H.A.R.M.
 - Heat
 - Alcohol
 - Running (exercise)/return to play
 - Massage
 - too soon after injury (the time will depend on the severity of the injury)

- **First aid requirements**
 - A first aid kit
 - Ice
 - Stretcher
 - Properly trained personnel in the use of such devices
 - A phone at the ground
 - Transport
 - Knowledge of the location of the nearest doctor, hospital, etc.

Whilst the law does affect sport more than ever before, this should not be seen as a negative. It is a positive reason to take the initiative to implement safe practices and risk management programs. There can be a great sense of achievement in knowing that Rugby League has satisfied its legal, moral and ethical duties by providing a safe sport that delivers quality programs.

Risk management really is all about quality coaching / officiating.

GROUND LOCATIONS

Ground Locations

Erina	Ilya ave Erina (opp Erina leagues club)
Blue Haven	Colorado Dr, Blue Haven
Berkeley Vale	Berkeley vale rd (off wyong rd)
Budgewoi-Buff point	Halekulani oval, Noela pl, budgewoi
Central Wyong	Watanobbi Oval, DE L'isle dr, Watanobbi
Gosford-Kariong	Carrington st Narara
Kincumber	Ozanam Park, cnr Empire bay dr & Mackillop rd kincumber south
Northlakes	Gumbuyah Oval, Tall Timbers Rd, Lake Munmorah
Ourimbah-Wyoming	Sohier Park, sohier st Ourimbah (near Uni)
St Edwards	St Edwards college oval, Russell Drysdale st East Gosford.
Terrigal-Wamberal	Brendan Franklin Oval, Beaufort Rd Terrigal
The Entrance	Edsacc Oval, The Entrance Rd Bateau Bay
Toukley	Darren Kennedy Oval, Cnr Oleander/Evans rd Toukley (car park entry via evans rd)
Umina	Umina Oval, Melbourne ave Umina
Woy Woy	Woy Woy Oval, Oval rd Woy Woy
Wyong	Morry Breen Complex , south end of Wyong Leagues Club, Kanwal (entry only at southern end of complex)

**USING MORRY
BREEN COMPLEX**

Using the Morry Breen and Bill Hicks Fields

All coaches and Managers should be aware of these arrangements and convey them to the parents and players

As you would be aware the traffic on all of the fields is very heavy each season, it is therefore necessary to control this usage by introducing some rules and guidelines to ensure the playing surfaces are kept in the best condition for the actual games.

Please keep in mind when reading these guidelines, the seniors players are paid professionals and as such they are expected to train and perform at their best and the club is expected to provide the training facilities.

It should be understood the Morry Breen field is primarily for use by the senior's football club, any variance to this is by arrangement only. One such arrangement is Minis training and game day. It is understood these is not enough field space on the Bill Hicks fields to accommodate the number of junior teams formed each season, this is why the Minis (who would do the minimum wear and tear) were granted the use of the Morry Breen field for their training and weekly games. With this arrangement it was also agreed that access to the Morry Breen field on training nights and game days was via the South end (Junior's) car parking area.

There is no access to juniors via the north car park and this is primarily for OH&S reasons. i.e. The safety of the kids from differing forms of heavy and light vehicle traffic through that car park. With this arrangement the Minis are to vacate Morry Breen field by 5.30pm every weekday

In a nut shell: No junior player is permitted on the Morry Breen field other than the agreed activities, coaches please advise your players to keep off

Wet Weather oval closures

Dane Cronin (Head Greenkeeper) will make a decision at 1 pm each day of wet weather.

The Juniors Web site www.wyongjuniorroos.com.au will be updated and should be the first point of information; failing this the players should contact their coaching staff who would have been advised. Please do not contact the leagues club's reception unless all other avenues have been exhausted

Yes!! you will see the seniors training when the fields are marked closed.

Head coach Paul Stringer has respect for the fields and where possible he will arrange alternative training such as a gym or boxing sessions, call a video viewing or use an alternative gym, there will be times when it is necessary for these players to use the wet ovals.

South west oval lights are on a three hour timer (turn on at 5pm) this will ensure the lights are not burning long after all training has ceased

Repetitive drills are to be done off the playing fields

Remember repetitive type drills which involve agility poles, tackle bag and the like, do the most damage, to protect the playing surface for actual game days, please when possible conduct your drills within the areas marked with black line marking, these are between the two fields and around the perimeter of the fields, the black lined areas are marked in 10 square metre plots

All junior teams are to complete training on the Bill Hicks fields by 6pm sharp (unless other arrangements have been agreed) please respect each others allotted times to avoid confrontation between coaches

Usage of the Gym

There should be limited requirements for juniors to use the gym. Matt Lavin (Sports Development Officer) is the only contact for all Gym activities. Matt will be working under very strict safety requirements with all Gym usage.

Peter Bryant
Football Administrator
Wyong Rugby League Club Group

SESSION PLAN

TRAINING PROGRAMME

Chapter 9

DATE: _____

SEASON SESSION No: _____

1. WARM-UP ACTIVITIES: _____

3. OTHER ACTIVITIES / GAMES: _____

4. WARM DOWN: _____

5. GEAR TO BE USED: _____

2. SKILLS & SKILL PRACTICES:

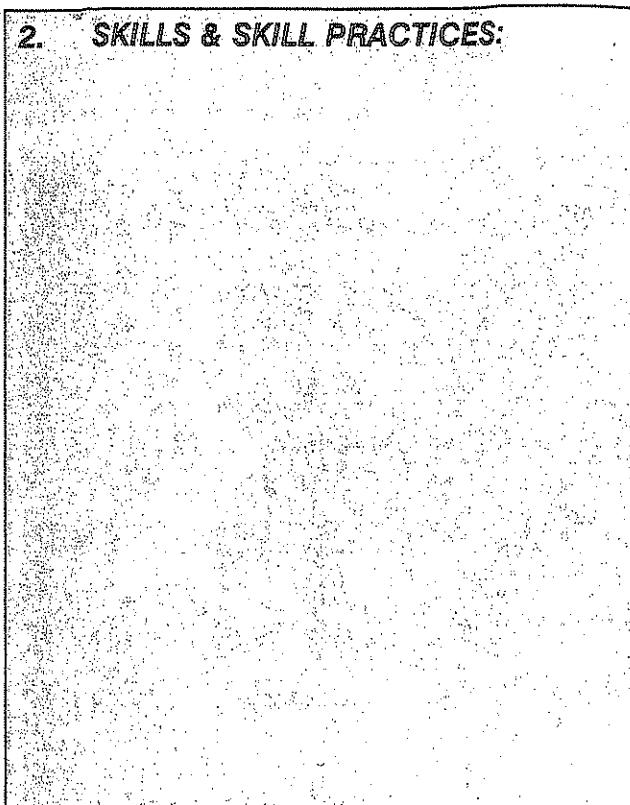

TRAINING PROGRAMME

DATE: _____

SEASON SESSION No: _____

1. WARM-UP ACTIVITIES: _____

3. OTHER ACTIVITIES / GAMES: _____

4. WARM DOWN: _____

5. GEAR TO BE USED: _____

2. SKILLS & SKILL PRACTICES:

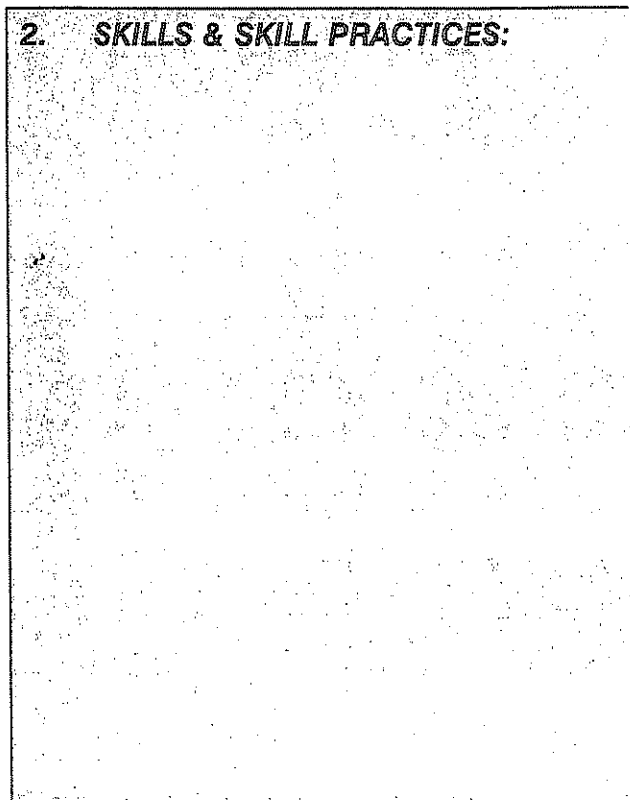

**PRE GAME / GAME
STATS SHEET**

PRE-GAME SHEET

Vs _____

Date : _____ Time : _____ Venue : _____ Age/Div : _____

Team	Name	Individual Goals / Areas of Concentration
1		
2		
3		
4		
5		
6		
7		
8		
9		
10		
11		
12		
13		
14		
15		
16		
17		
18		
19		
20		

TEAM GOALS :

- i) _____
- ii) _____
- iii) _____
- iv) _____
- v) _____

Pre Game – Warm Up Drills / Strategies	Organisational Matters

DEVELOPMENT PROGRAMS

5-7 YRS

JUNIOR PLAYER DEVELOPMENT PROGRAMME 5-7 YEARS

SKILL	SUB-SKILL	METHOD OF TEACHING	KEY POINTS OF SKILL								
HANDLING	Holding a Football	Technique – Handing Exercises and Practices	<ul style="list-style-type: none"> - Hand position on ball - Correct ball grip – fingers - Co-ordination – hand and body 								
	Picking up a Football	Drills and Technique Practice	<ul style="list-style-type: none"> - Hand and leg positions - Co-ordination – hand, eye, body, ball 								
	Falling on a Ball	Drills and Technique Practice	<ul style="list-style-type: none"> - Vision on ball - Body position and protection - Arm position and protection - Arm position over ball - Ground contact 								
	Catching a Ball	Drills Practices	Mini – eyes on ball, legs spread - body positioned								
	Scoring a Try	Technique Practices Drills	Ball control – hold properly Ground contact – body and ball								
PASSING & RECEIVING	Standing Pass	Drills Technique Practice	<ul style="list-style-type: none"> - Holding ball - Leg position - Arm swing - Accuracy 								
	Running Pass	Technique Drills (no pressure drills) Use bump pads for pressure drills ,if players are ready for next level	<table style="border: none;"> <tr> <td style="padding-right: 10px;">Holding ball</td> <td style="padding-right: 10px;">}</td> <td rowspan="4" style="vertical-align: middle;">Co-ordination of all movements</td> </tr> <tr> <td>Arm swing</td> <td>}</td> </tr> <tr> <td>Leg position</td> <td>}</td> </tr> <tr> <td>Target area</td> <td>}</td> </tr> </table>	Holding ball	}	Co-ordination of all movements	Arm swing	}	Leg position	}	Target area
Holding ball	}	Co-ordination of all movements									
Arm swing	}										
Leg position	}										
Target area	}										

REF: Y:WORDDATA/FOOTBALL/SNR/JOHN/PLAYERS PROGRAM TEMPLATE

Chapter 10

JUNIOR PLAYER DEVELOPMENT PROGRAMME 5-7 YEARS

SKILL	SUB-SKILL	METHOD OF TEACHING	KEY POINTS OF SKILL
PASSING & RECEIVING	Off the ground pass	Technique instruction & Practise	<ul style="list-style-type: none"> - Leg position - Arm swing - Eyes to target Timing of pass- target, accuracy Judgement
	Front on blocking	Technique instructions	<ul style="list-style-type: none"> - Position of head, arms, legs - Contact - Eyes open , chin up (looking pass target area) - Ground contact
TACKLING	Side on	Technique Instructions & Drills	<ul style="list-style-type: none"> - Position of head, arms, legs - Contact - Eyes open , chin up (looking pass target area) - Ground contact - Positioning & Timing
KICKING	Drop Kick	Technique Practise Drills	Holding ball correctly Eyes on ball Ball dropped correctly Leg moves straight through Contact point Timing } Co-ordination Balance
	Place kick	Technique Practise	Place ball correctly Eyes on ball Leg moves straight through Contact point Timing } Co-ordination Balance
RUCK PLAY	PLAY THE BALL	Techniques Instructions Drills	Position of the body Placement of ball on ground Foot contact (soft foot) Balance Co-ordination

JUNIOR PLAYER DEVELOPMENT PROGRAMME 5-7 YEARS

SKILL	SUB-SKILL	METHOD OF TEACHING	KEY POINTS OF SKILL
CONTACT	Fend	Technique practise Drills	<ul style="list-style-type: none"> - Ball carriage - Use of feet - Agility - Ball control - Arm placement
	Scrum 3 Man	Technique Instructions Practise	<ul style="list-style-type: none"> - Correct feet placement - Correct body size - Correct binding
FIELD	Draw & Pass (7)	Technique & Practise Drills	<ul style="list-style-type: none"> - Foot placement (passing off outside , catching off outside foot) - Hand position on ball - Body position - Vision - Timing
	Runaround (7)	Technique & Practise Drills	<ul style="list-style-type: none"> - Foot placement (passing off outside , catching off outside foot) - Hand position on ball - Body position - Vision - Timing
	Running Support (7)	Technique & Practise Drills	<ul style="list-style-type: none"> - Timing - Hand position to receive pass - Body position - Co-ordination

8-9 YRS

JUNIOR PLAYER DEVELOPMENT PROGRAMME 8-9 YEARS

SKILL	SUB-SKILL	METHOD OF TEACHING	KEY POINTS OF SKILL
HANDLING	Holding a Football	Technique – Handing Exercises and Practices	<ul style="list-style-type: none"> - Hand position on ball - Correct ball grip – fingers - Co-ordination – hand and body
	Picking up a Football	Drills and Technique Practice	<ul style="list-style-type: none"> - Hand and leg positions - Co-ordination – hand, eye, body, ball
	Falling on a Ball	Drills and Technique Practice	<ul style="list-style-type: none"> - Vision on ball - Body position and protection - Arm position and protection - Arm position over ball - Ground contact
	Catching a Ball & Catching high ball	Drills Practices	Mini – eyes on ball, legs spread - body positioned
	Scoring a Try	Technique Practices Drills	Ball control – hold properly Ground contact – body and ball
PASSING & RECEIVING	Standing Pass	Drills Technique Practice	<ul style="list-style-type: none"> - Holding ball - Leg position - Arm swing - Accuracy
	Running Pass	Technique Drills (no pressure drills) use bump pads for pressure drills ,if players are ready for next level	Holding ball } Arm swing } Leg position } Target area } Co-ordination of all movements

REF: Y:WORDDATA/FOOTBALL/SNR/JOHN/PLAYERS PROGRAM 8-9 YEARS

Chapota

JUNIOR PLAYER DEVELOPMENT PROGRAMME 8-9 YEARS

SKILL	SUB-SKILL		KEY POINTS OF SKILL
PASSING & RECEIVING <i>(continued)</i>	Off the ground pass	Technique instruction & Practise	<ul style="list-style-type: none"> - Leg position - Arm swing - Eyes to target Timing of pass- target, accuracy Judgement
	Inside Pass	Technique Instruction & Practise Drills	<ul style="list-style-type: none"> - Leg position - Arm swing - Eyes to target Timing of pass- target, accuracy Judgement
TACKLING	Front on blocking	Technique instructions	<ul style="list-style-type: none"> - Position of head, arms, legs - Contact - Eyes open , chin up (looking pass target area) - Ground contact
	Behind	Technique Instructions & Drills	<ul style="list-style-type: none"> - Position of head, arms, legs - Contact - Eyes open , chin up (looking pass target area) - Ground contact - Positioning & Timing
	Side on	Technique Instructions & Drills	<ul style="list-style-type: none"> - Position of head, arms, legs - Contact - Eyes open , chin up (looking pass target area) - Ground contact - Positioning & Timing

JUNIOR PLAYER DEVELOPMENT PROGRAMME 8-9 YEARS

SKILL	SUB-SKILL	METHOD OF TEACHING	KEY POINTS OF SKILL
KICKING	Drop Kick	Technique Practise Drills	Holding ball correctly Eyes on ball Ball dropped correctly Leg moves straight through Contact point Timing } Co-ordination Balance
	Grubber	Technique Practise Drills	Holding ball correctly Eyes on ball Ball dropped correctly Leg moves straight through Contact point Timing } Co-ordination Balance
	Chip	Technique Practise Drills	Holding ball correctly Eyes on ball Ball dropped correctly Leg moves straight through Contact point Timing } Co-ordination Balance
	Place kick	Technique Practise	Place ball correctly Eyes on ball Leg moves straight through Contact point Timing } Co-ordination Balance
RUCK PLAY	Play the Ball	Techniques Instructions Drills	Position of the body Placement of ball on ground Foot contact (soft foot) Balance Co-ordination

JUNIOR PLAYER DEVELOPMENT PROGRAMME 8-9 YEARS

SKILL	SUB-SKILL	METHOD OF TEACHING	KEY POINTS OF SKILL
CONTACT	Fend	Techinque practise Drills	<ul style="list-style-type: none"> - Ball carriage - Use of feet - Agility - Ball control - Arm placement
	Side step	Techinque practise Drills	<ul style="list-style-type: none"> - Ball carriage - Use of feet - Agility - Ball control - Balance - Co-ordination
	Scrums 3 Man	Technique Instructions Practise	<ul style="list-style-type: none"> - Correct feet placement - Correct body size - Correct binding
FIELD	Draw & Pass	Technique & Practise Drills	<ul style="list-style-type: none"> - Foot placement (passing off outside , catching off outside foot) - Hand position on ball - Body position - Vision - Timing
	Runaround	Techinque & Practise Drills	<ul style="list-style-type: none"> - Foot placement (passing off outside , catching off outside foot) - Hand position on ball - Body position - Vision - Timing
	Reverse Pass	Techinque & Practise Drills	<ul style="list-style-type: none"> - Hand position on ball - Body position - Vision - Timing

JUNIOR PLAYER DEVELOPMENT PROGRAMME 8-9 YEARS

SKILL	SUB-SKILL	METHOD OF TEACHING	KEY POINTS OF SKILL
FIELD <i>(continued)</i>	Angle of attack	Technique & Practise Drills	<ul style="list-style-type: none"> - Hand position on ball - Body position - Vision - Timing - Footwork (running correct lines)
	Running Support	Technique & Practise Drills	<ul style="list-style-type: none"> - Timing - hand position to receive pass - body position - co-ordination
DEFENCE POSITIONS	Front Line & Second Line	Practise Drills	<ul style="list-style-type: none"> - 7 in front line - fullback

10-12 YRS

JUNIOR PLAYER DEVELOPMENT PROGRAMME 10 - 12 YEARS

SKILL	SUB-SKILL	METHOD OF TEACHING	KEY POINTS OF SKILL
HANDLING	Holding a Football	Technique – Handing Exercises and Practices	<ul style="list-style-type: none"> - Hand position on ball - Correct ball grip – fingers - Co-ordination – hand and body
	Picking up a Football	Drills and Technique Practice	<ul style="list-style-type: none"> - Hand and leg positions - Co-ordination – hand, eye, body, ball
	Falling on a Ball	Drills and Technique Practice	<ul style="list-style-type: none"> - Vision on ball - Body position and protection - Arm position and protection - Arm position over ball - Ground contact
	Catching a Ball & Catching high ball	Drills Practices	<ul style="list-style-type: none"> - eyes on ball, legs spread - body positioned - Arms cradled - Jumping (off the ground) (12)
	Scoring a Try	Technique Practices Drills	<p>Ball control – hold properly</p> <p>Ground contact – body and ball</p>

REF: Y:WORDDATA/FOOTBALL/SNR/JOHN/PLAYERS PROGRAM 10 - 12 YEARS

JUNIOR PLAYER DEVELOPMENT PROGRAMME 10 - 12 YEARS

SKILL	SUB-SKILL		KEY POINTS OF SKILL									
PASSING & RECEIVING	Standing Pass	Drills Technique Practice	<ul style="list-style-type: none"> - Holding ball - Leg position - Arm swing - Accuracy 									
	Running Pass	Technique Drills (no pressure drills) Use bump pads for pressure drills, if players are ready for next level	<table style="width: 100%; border: none;"> <tr> <td style="width: 60%;">Holding ball</td> <td style="width: 5%; text-align: center;">}</td> <td rowspan="4" style="width: 35%; vertical-align: middle;">Co-ordination of all movements</td> </tr> <tr> <td>Arm swing</td> <td style="text-align: center;">}</td> </tr> <tr> <td>Leg position</td> <td style="text-align: center;">}</td> </tr> <tr> <td>Target area</td> <td style="text-align: center;">}</td> </tr> </table>	Holding ball	}	Co-ordination of all movements	Arm swing	}	Leg position	}	Target area	}
	Holding ball	}	Co-ordination of all movements									
	Arm swing	}										
Leg position	}											
Target area	}											
Off the ground pass	Technique instruction & Practise	<ul style="list-style-type: none"> - Leg position - Arm swing - Eyes to target Timing of pass- target, accuracy Judgement										
Inside Pass	Technique Instruction & Practise Drills	<ul style="list-style-type: none"> - Leg position - Arm swing - Eyes to target Timing of pass - target, accuracy Judgement										

JUNIOR PLAYER DEVELOPMENT PROGRAMME 10 – 12 YEARS

SKILL	SUB-SKILL	METHOD OF TEACHING	KEY POINTS OF SKILL
PASSING & RECEIVING <i>(continued)</i>	Scissor Pass(12)	Technique Instruction & Practise Drills	<ul style="list-style-type: none"> - Body Position - Vision - Positioning of passer and receiver - Timing of run
	Passing Variation (12) <ul style="list-style-type: none"> - Reverse - Spiral - Short - Pop - Around the Body 	Technique Instruction & Practise Drills	<ul style="list-style-type: none"> - Situation when pass can be affected - Timing of pass - Judgement of when to pass considering speed - Speed and distance of support
TACKLING	Front on blocking Front on Driving (12)	Technique instructions	<ul style="list-style-type: none"> - Position of head, arms, legs - Contact - Eyes open , chin up (looking pass target area) - Ground contact
	Behind	Technique Instructions & Drills	<ul style="list-style-type: none"> - Position of head, arms, legs - Contact - Eyes open, chin up (looking pass target area) - Ground contact - Positioning & Timing

JUNIOR PLAYER DEVELOPMENT PROGRAMME 10 - 12 YEARS

SKILL	SUB-SKILL	METHOD OF TEACHING	KEY POINTS OF SKILL
TACKLING <i>(continued)</i>	Side on	Technique Instructions & Drills	<ul style="list-style-type: none"> - Position of head, arms, legs - Contact - Eyes open , chin up (looking pass target area) - Ground contact - Positioning & Timing
	Smother	Technique Instructions & Drills	<ul style="list-style-type: none"> - Position of arms, body, legs in relation to ball carrier - Positioning and timing in conjunction with defence pattern
	Second man	Technique Instructions & Drills	<ul style="list-style-type: none"> - Position of arms, body, legs in relation to ball carrier - Contact - Eyes open, chin up (looking pass target area) - Target area (ball) - Ground contact - Positioning & Timing

JUNIOR PLAYER DEVELOPMENT PROGRAMME 10 - 12 YEARS

SKILL	SUB-SKILL	METHOD OF TEACHING	KEY POINTS OF SKILL
KICKING	Drop Kick	Technique Practise Drills	Holding ball correctly Eyes on ball Ball dropped correctly Leg moves straight through Contact point Timing } Co-ordination Balance
	Grubber Chip Across Kick (12)	Technique Practise Drills	Holding ball correctly Eyes on ball Ball dropped correctly Leg moves straight through Contact point Timing } Co-ordination Balance
	Punt - Orthodox - Torpedo - Drop	Technique Practise Drills	Holding ball correctly Eyes on ball Ball dropped correctly Leg moves straight through Contact point Timing } Co-ordination Balance

JUNIOR PLAYER DEVELOPMENT PROGRAMME 10 - 12 YEARS

SKILL	SUB-SKILL	METHOD OF TEACHING	KEY POINTS OF SKILL
KICKING <i>(continued)</i>	Place kick - Pendulum - Around the Corner	Technique Practise	<ul style="list-style-type: none"> - Place ball correctly - Eyes on ball - Leg moves straight through - Contact point - Timing } Co-ordination - Balance
	RUCK PLAY	Play the Ball	Techniques Instructions Drills
Marker		Techniques Instructions Drills	<ul style="list-style-type: none"> - Position of the body - Balance - Co-ordination - Stand back 1 metre from play the ball - Don't move until 1st receiver gets the ball - Pressure 1st receiver

JUNIOR PLAYER DEVELOPMENT PROGRAMME 10 – 12 YEARS

SKILL	SUB-SKILL	METHOD OF TEACHING	KEY POINTS OF SKILL
CONTACT / EVASION	Fend	Technique practise Drills	<ul style="list-style-type: none"> - Ball carriage - Use of feet - Agility - Ball control - Arm placement
	Side step	Technique practise Drills	<ul style="list-style-type: none"> - Ball carriage - Use of feet - Agility - Ball control - Balance - Co-ordination
	Change of Pace	Technique practise Drills	<ul style="list-style-type: none"> - Speed - Agility - Co-ordination
	Hit and Spin	Technique practise Drills	<ul style="list-style-type: none"> - Body positioning - Contact - Ball carriage - Use of feet - Ball control - Arm placement

JUNIOR PLAYER DEVELOPMENT PROGRAMME 10 – 12 YEARS

SKILL	SUB-SKILL	METHOD OF TEACHING	KEY POINTS OF SKILL
FIELD	Scrum 5 Man 6 Man (12)	Technique Instructions Practise	<ul style="list-style-type: none"> - Correct feet placement - Correct body size - Correct binding -
	Draw & Pass	Technique & Practise Drills	<ul style="list-style-type: none"> - Foot placement (passing off outside, catching off outside foot) - Hand position on ball - Body position - Vision - Timing
	Runaround	Technique & Practise Drills	<ul style="list-style-type: none"> - Foot placement (passing off outside, catching off outside foot) - Hand position on ball - Body position - Vision - Timing
	Reverse Pass	Technique & Practise Drills	<ul style="list-style-type: none"> - Hand position on ball - Body position - Vision - Timing

JUNIOR PLAYER DEVELOPMENT PROGRAMME 10 - 12 YEARS

SKILL	SUB-SKILL	METHOD OF TEACHING	KEY POINTS OF SKILL
FIELD <i>(continued)</i>	Angle of attack	Technique & Practise Drills	<ul style="list-style-type: none"> - Hand position on ball - Body position - Vision - Timing - Footwork (running correct lines)
	Running Support	Technique & Practise Drills	<ul style="list-style-type: none"> - Timing - hand position to receive pass - body position - co-ordination
DEFENCE POSITIONS	Front Line	Practise & Drills	<ul style="list-style-type: none"> - Position in conjunction of Defence Pattern
	Second Line Fullback / Wingers	Practise & Drills	<ul style="list-style-type: none"> - Correct positioning

13-16 YRS

JUNIOR PLAYER DEVELOPMENT PROGRAMME 13 – 16 YEARS

SKILL	SUB-SKILL	METHOD OF TEACHING	KEY POINTS OF SKILL
HANDLING	Holding a Football	Technique – Handing Exercises and Practices	<ul style="list-style-type: none"> - Hand position on ball - Correct ball grip – fingers - Co-ordination – hand and body
	Picking up a Football	Drills and Technique Practice	<ul style="list-style-type: none"> - Hand and leg positions - Co-ordination – hand, eye, body, ball
	Falling on a Ball	Drills and Technique Practice	<ul style="list-style-type: none"> - Vision on ball - Body position and protection - Arm position and protection - Arm position over ball - Ground contact
	Catching a Ball and Catching a High Ball	Drills Practices	<ul style="list-style-type: none"> - Eyes on ball, legs spread - Body positioned - Arms cradled - Jumping (off the ground) (12)
	Scoring a Try	Technique Practices Drills	<p>Ball control – hold properly</p> <p>Ground contact – body and ball</p>

JUNIOR PLAYER DEVELOPMENT PROGRAMME 13 - 16 YEARS

SKILL	SUB-SKILL	METHOD OF TEACHING	KEY POINTS OF SKILL
PASSING & RECEIVING <i>(continued)</i>	Scissor Pass (12)	Technique Instruction & Practise Drills	<ul style="list-style-type: none"> - Body Position - Vision - Positioning of passer and receiver - Timing of run
	Passing Variation (12) <ul style="list-style-type: none"> - Reverse - Spiral - Short - Pop - Around the Body 	Technique Instruction & Practise Drills	<ul style="list-style-type: none"> - Situation when pass can be affected - Timing of pass - Judgement of when to pass considering speed - Speed and distance of support
	Cut Out	Technique Instruction & Practise Drills	<ul style="list-style-type: none"> - Situation when pass can be affected - Timing of pass - Judgement of when to pass considering speed - Speed and distance of support
	Behind Pass	Technique Instruction & Practise Drills	<ul style="list-style-type: none"> - Situation when pass can be affected - Timing of pass - Judgement of when to pass considering speed - Speed and distance of support

JUNIOR PLAYER DEVELOPMENT PROGRAMME 13 – 16 YEARS

SKILL	SUB-SKILL	METHOD OF TEACHING	KEY POINTS OF SKILL
TACKLING	Front on Blocking Front on Driving (12)	Technique Instructions	<ul style="list-style-type: none"> - Position of head, arms, legs - Contact - Eyes open , chin up (looking pass target area) - Ground contact
	Behind	Technique Instructions & Drills	<ul style="list-style-type: none"> - Position of head, arms, legs - Contact - Eyes open, chin up (looking pass target area) - Ground contact - Positioning & Timing
	Side On	Technique Instructions & Drills	<ul style="list-style-type: none"> - Position of head, arms, legs - Contact - Eyes open , chin up (looking pass target area) - Ground contact - Positioning & Timing
	Smother	Technique Instructions & Drills	<ul style="list-style-type: none"> - Position of arms, body, legs in relation to ball carrier - Positioning and timing in conjunction with defence pattern

JUNIOR PLAYER DEVELOPMENT PROGRAMME 13 - 16 YEARS

SKILL	SUB-SKILL	METHOD OF TEACHING	KEY POINTS OF SKILL
TACKLING <i>(continued)</i>	Second Man	Technique Instructions & Drills	<ul style="list-style-type: none"> - Position of arms, body, legs in relation to ball carrier - Contact - Eyes open, chin up (looking pass target area) - Target area (ball) - Ground contact - Positioning & Timing
	Ball & All	Technique Instructions & Drills	<ul style="list-style-type: none"> - Position of arms, body, legs in relation to ball carrier - Contact - Eyes open, chin up (looking pass target area) - Target area (ball) - Ground contact - Positioning & Timing
KICKING	Drop Kick	Technique Practise Drills	Holding ball correctly Eyes on ball Ball dropped correctly Leg moves straight through Contact point Timing } Co-ordination Balance

JUNIOR PLAYER DEVELOPMENT PROGRAMME 13 - 16 YEARS

SKILL	SUB-SKILL	METHOD OF TEACHING	KEY POINTS OF SKILL
KICKING <i>(continued)</i>	Grubber Chip Across Kick (12)	Technique Practise Drills	Holding ball correctly Eyes on ball Ball dropped correctly Leg moves straight through Contact point Timing } Co-ordination Balance
	Punt - Orthodox - Torpedo - Drop	Technique Practise Drills	Holding ball correctly Eyes on ball Ball dropped correctly Leg moves straight through Contact point Timing } Co-ordination Balance
	Bombs	Technique Practise Drills	Holding ball correctly Eyes on ball Ball dropped correctly Leg moves straight through Contact point Timing } Co-ordination Balance

JUNIOR PLAYER DEVELOPMENT PROGRAMME 13 - 16 YEARS

SKILL	SUB-SKILL	METHOD OF TEACHING	KEY POINTS OF SKILL
KICKING <i>(continued)</i>	Place Kick - Pendulum - Around the Corner	Technique Practise	<ul style="list-style-type: none"> - Place ball correctly - Eyes on ball - Leg moves straight through - Contact point - Timing } Co-ordination - Balance
	RUCK PLAY	Play the Ball	Techniques Instructions Drills
	Marker	Techniques Instructions Drills	<ul style="list-style-type: none"> - Position of the body - Balance - Co-ordination - Stand back 1 metre from play the ball - Position in coaches marker play, ie first marker chases, second marker fill in hole

JUNIOR PLAYER DEVELOPMENT PROGRAMME 13 - 16 YEARS

SKILL	SUB-SKILL	METHOD OF TEACHING	KEY POINTS OF SKILL
CONTACT / EVASION	Fend	Technique practise Drills	<ul style="list-style-type: none"> - Ball carriage - Use of feet - Agility - Ball control - Arm placement
	Side Step	Technique practise Drills	<ul style="list-style-type: none"> - Ball carriage - Use of feet - Agility - Ball control - Balance - Co-ordination
	Change of Pace	Technique practise Drills	<ul style="list-style-type: none"> - Speed - Agility - Co-orindation
	Hit and Spin	Technique practise Drills	<ul style="list-style-type: none"> - Body positioning - Contact - Ball carriage - Use of feet - Ball control - Arm placement

JUNIOR PLAYER DEVELOPMENT PROGRAMME 13-16 YEARS

SKILL	SUB-SKILL	METHOD OF TEACHING	KEY POINTS OF SKILL
CONTACT / EVASION <i>(continued)</i>	Swerve	Technique practise Drills	<ul style="list-style-type: none"> - Body positioning - Contact - Ball carriage - Use of feet - Ball control - Arm placement
	In and Away	Technique practise Drills	<ul style="list-style-type: none"> - Body positioning - Contact - Ball carriage - Use of feet - Ball control - Arm placement
FIELD	Scrum	Technique Instructions Practise	<ul style="list-style-type: none"> - Correct feet placement - Correct body size - Correct binding -
	Draw & Pass	Technique & Practise Drills	<ul style="list-style-type: none"> - Foot placement (passing off outside, catching off outside foot) - Hand position on ball - Body position - Vision - Timing

JUNIOR PLAYER DEVELOPMENT PROGRAMME 13 - 16 YEARS

SKILL	SUB-SKILL	METHOD OF TEACHING	KEY POINTS OF SKILL
FIELD <i>(continued)</i>	Runaround	Technique & Practise Drills	<ul style="list-style-type: none"> - Foot placement (passing off outside, catching off outside foot) - Hand position on ball - Body position - Vision - Timing
	Reverse Pass	Technique & Practise Drills	<ul style="list-style-type: none"> - Hand position on ball - Body position - Vision - Timing
	Angle of Attack	Technique & Practise Drills	<ul style="list-style-type: none"> - Hand position on ball - Body position - Vision - Timing - Footwork (running correct lines)
	Running Support	Technique & Practise Drills	<ul style="list-style-type: none"> - Timing - Hand position to receive pass - Body position - Co-ordination

JUNIOR PLAYER DEVELOPMENT PROGRAMME 13 - 16 YEARS

SKILL	SUB-SKILL	METHOD OF TEACHING	KEY POINTS OF SKILL
FIELD <i>(continued)</i>	Running Lines	Technique & Practise Drills	<ul style="list-style-type: none"> - Timing - Hand position to receive pass - Body position - Co-ordination
	Running Off the Ball	Technique & Practise Drills	<ul style="list-style-type: none"> - Timing - Hand position to receive pass - Body position - Co-ordination
	Running Decoys	Technique & Practise Drills	<ul style="list-style-type: none"> - Timing - Hand position to receive pass - body position - co-ordination
DEFENCE POSITIONS	Front Line	Practise & Drills	<ul style="list-style-type: none"> - Position in conjunction of Defence Pattern
	Second Line	Practise & Drills	<ul style="list-style-type: none"> - Correct positioning
	Fullback / Wingers	Practise & Drills	<ul style="list-style-type: none"> - Correct positioning

FUNCTION OF A DRILL

Consider the function of a drill

By Phil Hertz

How far have we come? Rugby League training once consisted of three laps of the oval, a couple of toe touches, 20 minutes of sprints and a half an hour of "ball work". But then someone invented the "drill". The drill was the saviour!!

Now there are drills for passing, receiving, tackling, kicking and all the skills. Young coaches use them, old coaches use them, mini coaches, mod coaches and International Laws coaches use them. In fact, there is a disease - D.O.D. Drills Overload Disease.

You see some coaches use drills and haven't got the foggiest idea why, how or when to run them. Drills are observed by some coaches and immediately put in their ever changing repertoire of "training methods".

Drills are not complete coaching sessions but form only a part of them. Lets stop for a minute and consider a few things.

When we want to do a drill with our players what should we consider? Obviously the realisation of what we want to practise is important!! Will the drill meet the result we are looking for? Improve our players' skills or the team play?

What are the function of drills:

1. Warm-up activity?
2. Re-enforcement, practice? (Drilling it in)
3. Learning?

There are a lot of questions that need answering. This article will give you the questions you need to consider, and you must supply the answers.

Firstly, what skill or play factors are we wanting to improve? You must first and foremost identify what we want to achieve?

The practical part of the drill is next, it needs to be designed - how will it work?

How many players will be involved? Remember we don't want a "super" drill that only six players can do while the rest of the team is standing idle. What active time is involved? Have we got a good rotation so all players are performing each section of the drill?

Is your new drill suitable for all ages or just your team?

What equipment is needed? How long does it take to set up? How long would it run? Is there a suitable rest time included?

It is amazing that coaches program drills to operate without any consideration to the fitness strain on players. How many coaches actually try out their drills personally prior to exposing their players to it?

Having decided that your "new drill" will meet your goal it must be easy to explain. You must be able to explain to your players why they are doing it and what benefits will accrue. Players must be able to witness their improvement.

Now maybe is the time to remind ourselves to assess if the drill is achieving our goal? Well is it? Or does it simply look good because no one is dropping the ball or whatever? If it isn't, you may have to adjust it a little, or a lot, but don't let it continue without a purpose.

Increasing pressure through the elements of time and space and emphasising skill technique will separate a drill from an activity.

Okay, so it is going well, achieving your goals and the players are learning as well as enjoying the drill. Can you explain it to someone else, verbally or written, perhaps you have to do it or demonstrate it.

There's a technique involved. Maybe have a look at other people's style and come up with your own. But why not share it? After all, before you designed your "new drill", where did you get all your others from?

Remember:

1. Identify what you want to do. Come up with a problem?
2. Plan it, design how it works, reconstruct that segment of play on a small isolated basis.
3. Put it in working order, test it.
4. Conduct it.
5. Refine it.

And it works, it really achieves your goal. It's a good feeling! You may even be classed as an innovator in time to come!! GOOD LUCK.

SUGGESTED OPTION PLAYS

Suggested Option Plays

Please note- coaches should determine which is appropriate for the age/level that they are coaching.

Heads- cut out pass to outside runner (face ball)

Tails- Pass behind a wedge runner to sweep or straight runner coming from behind the 1st runner (wedge) comes from outside to sell marker.

Split- Cut out pass through 2 players ball goes in front of (a) player & behind (b) player and hits (c) runner.

A- Drop off pass to runner coming inside.

AA-

Show to 1st inside runner and hand off to 2nd inside runner.

A+ Show to inside runner passing to outside runner.

DD- Double tails 2 wedge runners with the ball hitting the (c) player.

Gunya- Long clearing kick.

Putter- Short kick along ground.

Blue- Bomb

Broncos- Across field bomb to outside backs.

Titans- A.D.H runs and shows the ball to (a) runner and has 2 more players on the outside (b) runner running straight A+ line (c) player running the AA line will get the ball.

Subway- From the scrum ½ passes to 5/8, ½ does run around and picks up outside player on a tails move, player running through as option can be any player.

Subway2- ½ passes to 5/8 .1/2 does run around 5/8 in one move dummies to ½ and picks up runner coming on the inside, player running through as option can be any player.

Two dog- Same as tails but with 2 wedge runners and pick up tails runner.

Spilt Combo- From A.D.H we have split followed by DD.

DD Combo- From A.D.H we have a DD followed by a titan

NUTRITION & RECOVERY

NUTRITION

The game of Rugby League and training places great stresses on the body. It is essential that the layers of the game follow a sound nutritional diet. A player must fuel his/her body with the right energy to meet the demands of Rugby League.

Pre Game Meal:

Before a game a player needs fuel for the body. Food high in carbohydrates are required. Food high in fat should be avoided.

Suggested Breakfast options:

- ◆ Grained bread
- ◆ Baked beans on toast (no butter)
- ◆ Raisin toast
- ◆ Crumpets/muffins/scones/pancakes
- ◆ Muesli
- ◆ Low fat yoghurt
- ◆ Fruit
- ◆ Fruit Juice
- ◆ No milk
- ◆ Toppings: Sliced banana, golden syrup, honey.

Post Game Meal:

After a game there is a 20 minute 'window of opportunity' for players to re-fuel their body. Food high in carbohydrates (simple carbs) are required.

- ◆ Hydrate with fluids such as 'powerade' Avoid fluids such as 'red bull' & 'Mother'
- ◆ Raisin toast
- ◆ Red frogs
- ◆ Muffins
- ◆ Honey

After 20 minutes a player should have a high carbohydrate meal within 2 hours.

- ◆ Spaghetti
- ◆ Pasta
- ◆ Sandwiches

Healthy eating for kids

Healthy eating means eating a wide variety of nutritious foods from all of the food groups. These foods contain lots of vitamins, minerals and fibre. Eating a wide variety of foods from all food groups will help you grow.

Some foods contain too much sugar or fat and not many vitamins or minerals. These are foods we should only eat sometimes.

The foods you eat have been divided into three groups according to how nutritious they are. These make up what is often called the 'food pyramid'. You can use these groups to help you decide which foods to eat more of and which to eat less often.

Group 1: Eat these foods most of the time

You should try to eat lots of:

- Fruits and vegetables
- Breads
- Grains such as rice and pasta
- Beans and lentils.

You can see that these are all foods that come from plants. These foods all contain vitamins, minerals and fibre. Try to eat a wide variety of these foods. Try not to choose just one of these foods (such as fruit) to eat all the time. Eating plenty of **all** foods from this group will help you stay healthy.

Plant foods contain thousands of nutrients (small parts), which can help to prevent serious diseases. This is why it is important to eat a variety of different types of plant foods.

Group 2: Eat these foods moderately

These foods are important for health, so you should eat them in medium amounts:

- Dairy products such as milk, cheeses and yoghurts (sometimes low fat ones should be chosen)
- Lean meat
- Chicken (without skin)
- Fish
- Nuts.

These foods are all good sources of protein. Protein helps build strong muscles and can repair our body when we hurt or injure ourselves. Some of these foods also contain some important minerals, such as the calcium found in dairy foods (for strong bones) and the iron found in lean meats (to give us energy).

Group 3: Eat these foods sometimes

These foods don't give us very many nutrients and are really just 'extras'. They may contain lots of sugar or fat (or both) but often don't have many vitamins, minerals or fibre. It's OK to have these 'sometimes foods' if you are healthy, active and not overweight. Most of the time they are better left for occasions like birthday parties.

An example of one serve of these foods includes:

- Sweet biscuits (2 small)
- Chocolate coated bars (1 bar)
- Potato chips (30g)
- Ice-cream (2 scoops)
- Lollies/chocolate (30g)
- Cake or muffin (1 medium piece).

The food pyramid

The three groups of foods you eat from are often shown as a food pyramid:

- The bottom of the pyramid** is the biggest part of the pyramid. It contains the foods you should eat most of the time.
- The middle of the pyramid** contains foods you should eat moderately (a medium amount). They are important

SCRUMS

MINI

SCRUM

Scrum, should they occur in Mini Footy, will consist of three (3) players from each team who are to be correctly bound in the accepted fashion. A scrum shall be packed only when -

- (a) there is an infringement by BOTH sides, e.g. a double knock-on, except after three (3) play-the-balls.
- (b) the ball-carrier is held up over his opponent's goal line, except after three (3) play-the-balls.

- (c) from a penalty kick the ball is touched by a member of the non-kicking team before entering touch.
- (d) there is an infringement involving the referee, a touch judge or a spectator.

On other occasions when a scrum would have been set the ball merely “changes hands” and the non-offending side plays the ball. The two lines of forwards **MUST** pack with their backs parallel to the ground and face their opponents’ goal line till the ball has emerged properly from the scrum. **NO PUSHING, PULLING OR ROTATING A SCRUM IS PERMITTED. ONLY the hooker may STRIKE for the ball** and, then, only after it has touched the ground along the centre-line of the scrum beyond the inner feet of the loose head forwards. The hooker must keep one foot on the ground at all times. **All prop forwards MUST keep both feet on the ground at all times apart from the act of re-gaining balance.** At all scrums, the ball must emerge as shown in the diagram below.

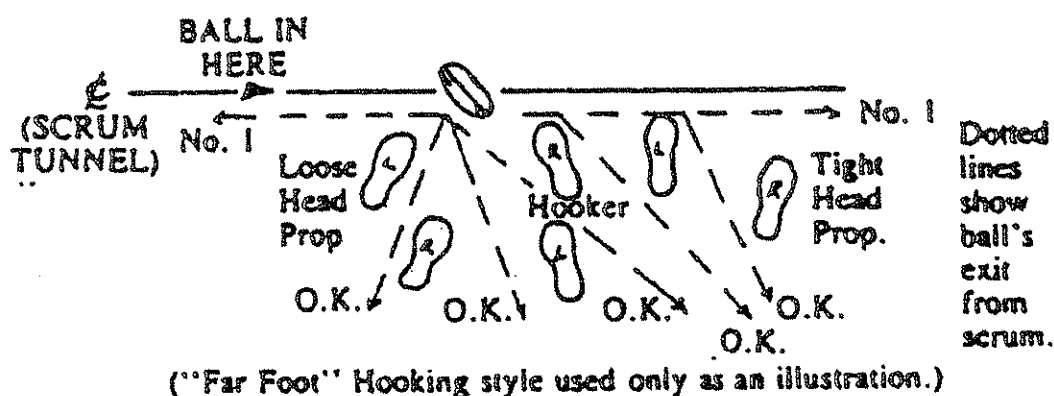

The FEEDING of the scrums is in accordance with adult Laws. The “non-feeding” halfback must adopt a position behind the scrum and the “feeding” halfback must retire behind the scrum immediately after the put-in. In Mini Footy, all players NOT in the scrum, are to retire behind their row of forwards. When the ball emerges correctly from the scrum and is picked up by an on-side player, that player may either run or pass the ball but must not be caught in possession. If this ball-carrier runs but does not score and is tackled with the ball while running in the field of play, a change of possession occurs and will be signalled in the prescribed adult fashion. If the player gains possession, but is unable to either run or pass the ball and is tackled, then play continues with a play-the-ball ... i.e. 1st tackle.

MOD

SCRUM

A scrum at ages 9, 10 & 11 years, will consist of five (5) players; and, at age 12 years, six (6) players. Three (3) players are to be correctly bound as a "front" row. Two (2) players are to be correctly bound as a "second" row and they are to bind with the front row so that their heads are placed in the two spaces between the hooker and the front row forwards. At 12 years an additional player "locks" the scrum.

A scrum shall be packed ONLY when -

- (a) there is an infringement by BOTH sides, e.g. a double knock-on, except after five (5) play-the-balls;
- (b) the ball-carrier is held up over the opponent's goal line, except after five (5) play-the-balls;
- (c) from a penalty kick the ball is touched by a member of the non-kicking team before entering touch.
- (d) there is an infringement involving the referee, a touch judge or a spectator.

Adult Law stipulations, re injured players, will always operate.

The following will apply when a kick for touch is attempted other than at a penalty kick.

- (a) If the kick goes into touch on the full, play is restarted by a change of possession to the non-kicking team and the play-the-ball taken back where the kick originated except when the ball is kicked backwards and then it is brought 10m. in-field opposite where the ball crossed the touch line.

The manner of feeding the scrums is in accordance with the adult Laws. The “non-feeding” halfback must adopt a position behind the scrum and the “feeding” halfback must retire behind the scrum immediately after the put-in. In Mod League, all players NOT in the scrum, are to retire behind their last row of forwards. When the ball emerges correctly from the scrum and is picked up by an on-side player then that player may either run or pass the ball but must not be caught in possession. If this ball-carrier is tackled with the ball while running in the field of play - unless scoring, a change of possession occurs.

If the player, who receives the ball from the scrum, is unable to either run or pass the ball and is tackled then play continues with a play-the-ball ... i.e. 1st tackle.

At any changeover the referee’s signal will be in accordance with adult Law.

NOTE

In 12 years Mod League, the halfback (or whomever receives the ball from the scrum), may run from the scrum, after winning the ball, without the risk of forfeiting possession.

(a) at 9-11 Yrs.

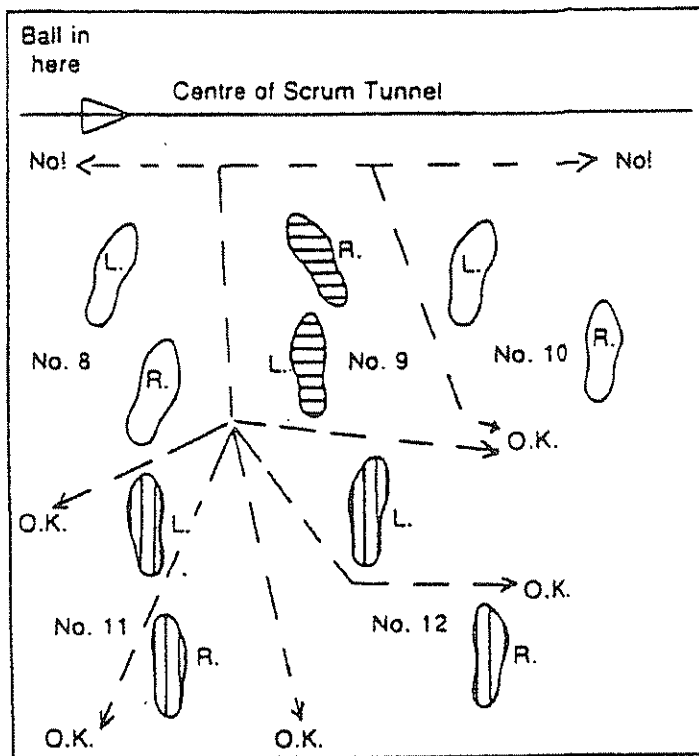

The correct feet positions for a good, tight-packing scrum. Dotted lines show ball's "exit" possibilities. "Far Foot" hooking style used only as an illustration.

(b) at 12 Yrs.

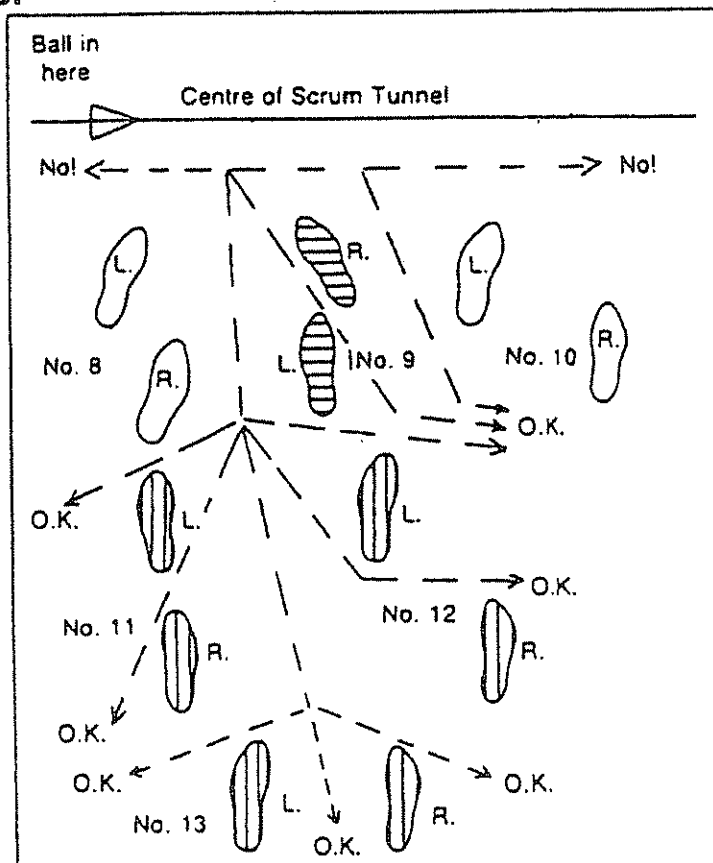

- (b) If the kick lands first in the field of play and then goes into touch there is a change of possession and a play-the-ball taken, by the non-kicking team, where the scrum would usually have been set, with the tackle count to be "zero".
- (c) If the ball is deliberately played at by a member of the non-kicking side and then goes into touch, a member of the kicker's team plays the ball where the scrum would usually have been set. "Zero" tackle count.
- (d) If the ball ricochets or rebounds from a member of the non-kicking team and then goes into touch, a member of the non-kicking team will play the ball where the scrum would usually have been set. Tackle count to be "1".

On other occasions when a scrum would have been set the ball merely "changes hands" and the non-offending side plays the ball. The two sets of forwards **MUST** pack with their backs parallel to the ground and face their opponents' goal line till the ball has emerged properly from the scrum.

NO PUSHING, PULLING OR ROTATING A SCRUM IS PERMITTED.

ONLY the hookers may STRIKE for the ball and, then, only after it has touched the ground beyond the inner feet of the loose head forwards. The hooker must have one foot on the ground at all times. **All prop forwards MUST keep BOTH feet on the ground apart from the act of gaining or re-gaining balance.** In all scrums, the ball **MUST** emerge from behind the **INSIDE** legs of the **PROP FORWARDS** (see diagram).

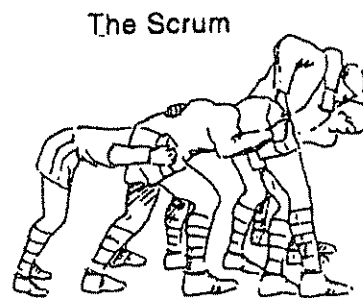
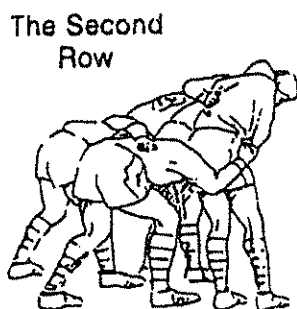
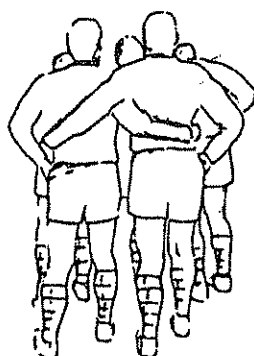
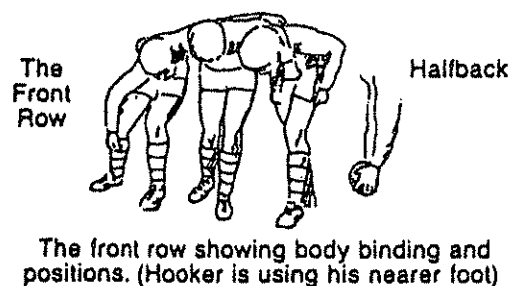
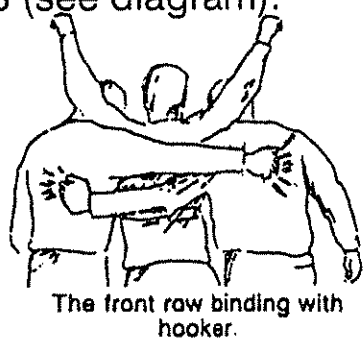

DRILLS & GAMES

RUGBY
LEAGUE
COACHING
MAGAZINE

Since 1993



Learn the game
you love!

www.rlcm.com.au

HANDBOOKS 1 - 6

- | | | |
|----------------|-----------------------|----------------------|
| Book 1. | Drills | Pages 2 - 5 |
| Book 2. | Games | Pages 6 - 9 |
| Book 3. | Mini & Mod | Pages 10 - 17 |
| Book 4. | Kicking | Pages 18 - 21 |
| Book 5. | Defence | Pages 22 - 25 |
| Book 6. | Drills | Pages 26 - 29 |

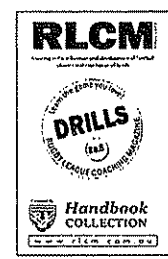
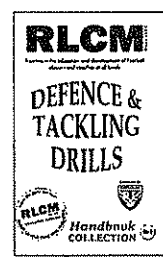
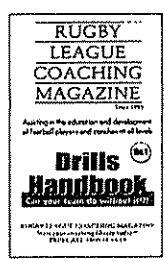

If desired cut pages where indicated and fold to make pocket size handbooks that can be easily referred to while on the training field.

A RLCM Publication

PLAY THE BALL (Fours)

SETTING: Open Space
Groups of four players
1 football per group

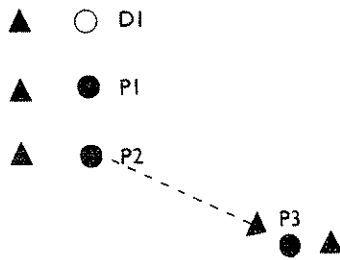

GUIDELINES:
Player 1 plays the ball to P2 the acting half back. P2 passes to P3. D1 is the defence marker.
Rotate the position of each player after each play the ball.
Ensure proper technique in the play the ball.
Marker can apply pressure to the play the ball.
Player playing the ball should start from a tackled position on the ground.

COACHING POINTS

1. Tackled player (P1) to regain feet as quickly as possible.
2. Football held securely.
3. Football placed on ground correctly.
4. Control of football with the foot.
5. Good even roll of the ball back with foot.

SIDE STEP (TECHNIQUE)

GAME SKILLS:

- Sidestep
- Speed
- Hand Off Pass

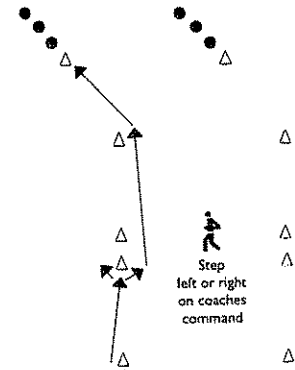

GUIDELINES:

- Set up two sets of markers as per diagram, with approximately 6 players per team, with 3 at each end.
- On a signal, the players with a ball run to the first marker and sidestep to run to the second dome where they step again, either foot
- Players step again at the last marker and hand off the ball to the next player and so on until the relay is completed.

NOTE

- Many players will attempt to shuffle around markers rather than step. Keep correcting.
- Young players may need to start with a simpler version to assure correct technique.

Cut—

PLAY THE BALL RELAY

SETTING:
2 Markers
4 Players
1 Football

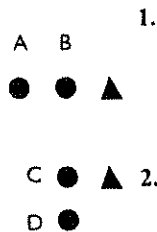

GUIDELINES:

- Distance between markers 1 - 2 metres
- Player A plays the ball to player B.
- Player B passes the ball off the ground to player C.
- Player A runs behind player D.
- Player C passes (standing) the ball back to player B.
- Player B keeps ball and moves to player A's original position.
- Player c runs to marker and takes up player B's original position.
- Drill is repeated involving player B, C and D and so on...

N.B. Change drill so that players are passing left to right.
No 'baby passes'.

RLCM **BOOK 1 DRILLS**

HIT and SPIN

SETTING: Open space
2 Markers
1 Bump shield (Hit pad)
1 Football

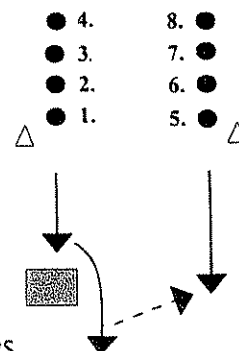

PASSING PAIRS

No 1 runs with the ball in both hands and bursts onto the shield that is held at waist height by another player.

He hits, spins and passes to support that has come with him on left. both players then retire behind their respective lines.

Another pair of lines are set up similarly but pass in the opposite direction.

SWERVE RELAY

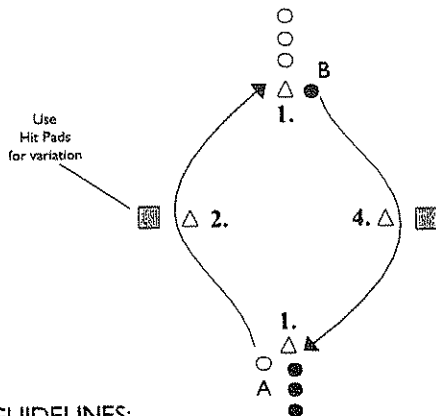

GUIDELINES:

- Player A starts running from marker 1 around marker 2 and handing off to player B at marker 3.
- Player B repeats the exercise in the opposite direction rounding marker 4 and handing off to player C at marker 1.
- Once a player has run they must return to the end of the line.
- The drill can be run as a relay race between two teams competing on different courses.
- The cycle is reversed regularly to ensure right and left swerves are developed.
- Keep drill as small as possible to reflect a game situation.

VARIATION Hits pads on markers 2 and 4 to apply running pressure and promote running balance.

PLAY THE BALL (Sixes)

SETTING: Open Space
Groups of six players
1 football per group

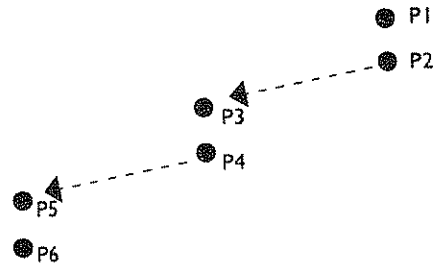

GUIDELINES:

Player 1 commences on the ground. On the command P1 regains his feet and quickly plays the ball to P2. P2 passes to P3 from the ground. P3 falls to the ground then regains his feet and plays the ball to P4, then P5 and P6 continuing drill.

When P6 receives the ball all players about turn and the ball is worked back along the line in the same way until P1 regains possession.

Ensure good technique is practiced.

Cut —

2 on 1 EVASION

SETTING: Grid 10m X 10m
3 Players

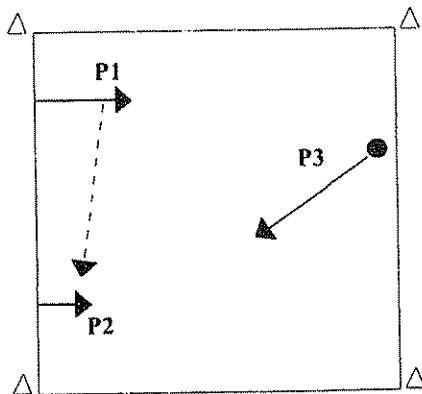

Three players to a grid 10m x 10m. player 1 passes to 2 with plenty of room to move and he attempts to beat 3 with a fend, swerve, side-step or change of pace. 3 attempts to tackle him although he is not allowed to start defending until the ball has left player 1's hands.

N.B. While player 2 gets the ball early, player 3 must wait for the ball to leave player 1's hands before moving.

RLCM BOOK 1 DRILLS

SNAKES & LADDERS (TECHNIQUE)

SETTING: Grid 15m X 5m
8 Markers
5 Players
1 Football

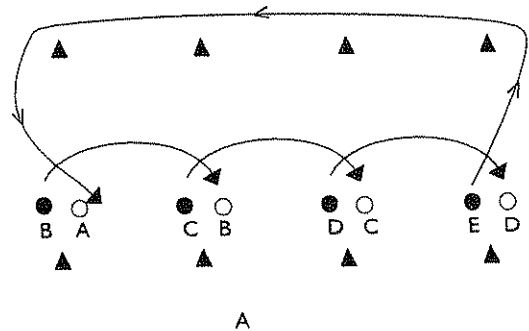

GUIDELINES:

- Player A starts and plays the ball to player B.
- Player B runs out and around in front of player C. Player B then plays the ball.
- Player C then runs out and around in front of player D. Player C then plays the ball.
- Player D then runs out and around in front of player E. Player D then plays the ball.
- Player E then runs around the side of the grid and runs out and around in front of player A. Player E then plays the ball to player A who begins the routine again.

PASSING KAMIKAZE DRILL

SETTING: 4 Footballs, Groups of 4 players, 4 markers

GAME SKILLS: Passing, Evasion, Vision, Communication

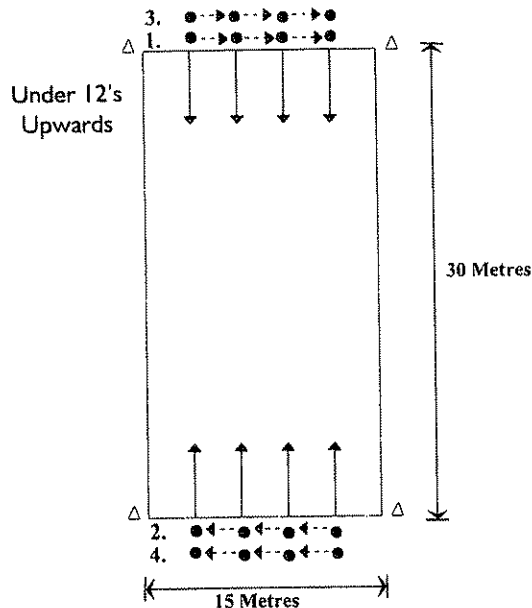

Teams 1 and 2 commence jogging and passing, on reaching the halfway mark, teams 3 and 4 commence.

On approaching, teams will avoid each other but continue to pass as they run between the on-coming team.

DEFENSIVE LINE POSITIONING

SETTING: Field Positions

GAME SKILLS: Organisation, Communication

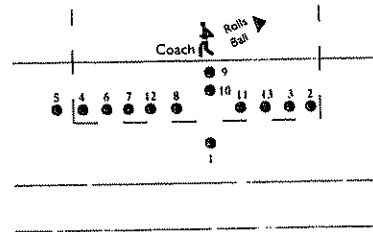

- Players line up as a team in their appropriate defensive line positions (diagram is simply a suggestion).
- Coach who starts with the ball rolls it anywhere on the field.
- The defensive line advances and the two nearest defenders drop on the ball.
- This represents a tackle.
- Meanwhile the rest of the defensive line should reposition themselves accordingly
- The fullback (1) should communicate with the line to ensure there are no obvious gaps.
- The ball is then given back to the coach in a new position and the sequence commences again.

N.B. Ensure that the coach varies the distance and angle of the roll.

Cut—

WARM-UP HANDLING DRILL

SETTING: Grid 10m X 10m
4 Groups of players
1 - 2 Footballs

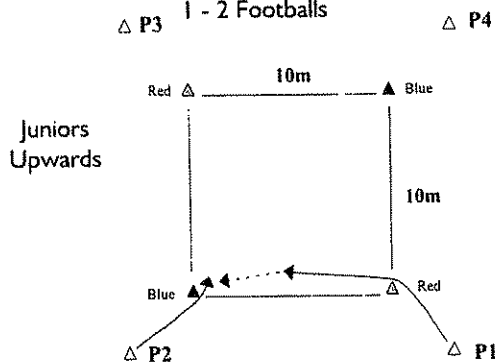

VARIOUS BALL HANDLING EXERCISES

Start

1. Player from group 1 commences running and passes off to P2 who times run from marker to accept an outside pass from P1, P2 - P3, P3 - P4 etc.
2. Inside pass at each corner.
3. On blue markers ball placed on ground, then picked up from ground by blue marker player and passed off at red marker.

VARIATIONS: i) Introduce 2 footballs
ii) Change direction of run

SIDE ON DEFENCE (TECHNIQUE)

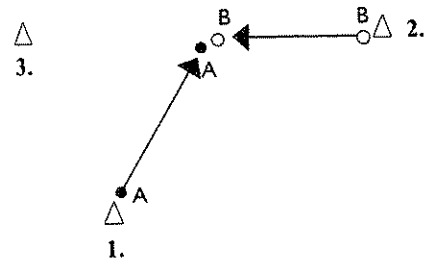

GUIDELINES:

- Player B walks with ball in a direct line from marker 2 to marker 3
- Player A approaches from marker 1 and pushes player B with his left shoulder

N.B. Player A has his arms pointing straight out like an aeroplane and aims to hit the thigh of player B

VARIATION:

- Player B runs from marker 3 to marker 2 so that A uses his right shoulder
- Performed in the same manner as drill A except both player A and B are jogging not walking.
- This time using the same basic drill player A effects a tackle on player B. Both players are jogging.

DEFENCE LINE COMMUNICATION

SETTING: Open space or suggested channel approx. 40m x 20m
4 to 6 players; 10 markers

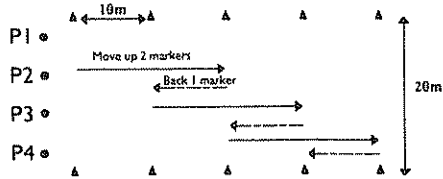

- 4 Players form a line at one end of channel.
- Players at end of channel move up 2 marker distances
- Then retreat back 1 marker by half turning to run back to line then turning to face front again.
- Drill continues length of channel. (ie up 2 back 1)

OBJECTIVE

- Communication
- Adjustment of defensive line
- Speed back to regroup line.
- Working together
- Speed of the line

(b) PROGRESSION

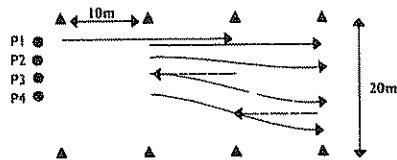

Similar to (a) except players alternate start on either left or right side of channel compressed together. As they move forward players spread out to cover the full width of the channel. As they move back they adjust to compress the defensive line before moving forward again.

Cut

ZIG ZAG RELAY

SETTING: Groups of 6 players
Distance will depend on age group
6 Markers, 1 Football

GAME SKILLS: Handling, Passing, Running with the ball

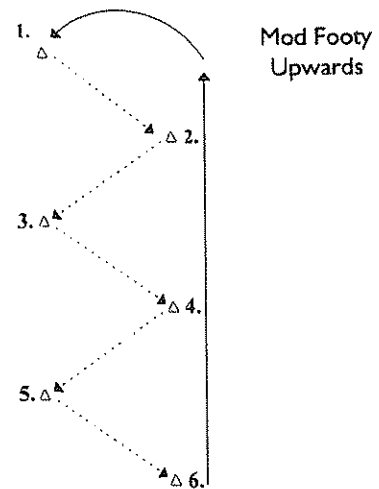

The ball starts at Position 1. The ball is passed in Zig Zag fashion to Position 6. The player at 6 in possession of the ball runs to Position 1, while all other players shuffle to the next station.

VARIATION: Player at Position 6 perform a Grubber or Chip kick while running to position 1.

BEHIND TACKLE (TECHNIQUE)

SETTING: Players in 2 teams
Open space distance determined by age group
1 Football
4 Markers

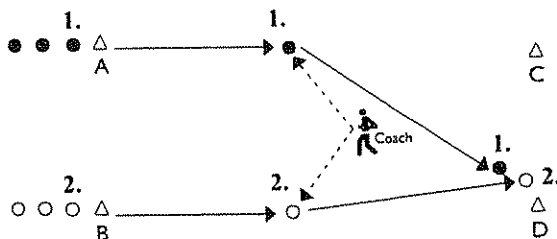

- Players form two equal lines behind markers A and B
- On call players 1 and 2 run in a straight line
- The coach chooses to pass to either player
- The player who receives the ball attempts to score a try between markers C and D
- The defending player attempts to tackle his opposite from behind.

RLCM BOOK 1 DRILLS

NEIGHBOURS

SETTING: 12m X 12m grid, 2 Footballs
8 Markers

GAME SKILLS: Passing, Handling
Communication, Vision, Reaction

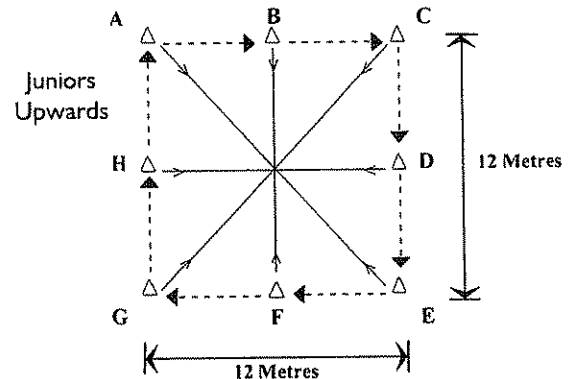

Eight players take up positions next to the markers. Players on positions A and E begin with the ball.

On the command "go" players A and E pass to their left and then swap positions. F and B receive the ball and pass to the left and then swap positions. The drill continues with the ball moving clockwise around the rectangle and players swapping with their direct opposite. Attempt to work for three minutes.

VARIATIONS: i) Players pass anti-clockwise
ii) Start ball at H and E and use "cut-out" pass, follow your pass and take up that station.

Page 5

TEN PASSES

- SETTING:**
- Grid 15m x 15m
 - 2 Equal teams of players
 - 4 Markers • 1 Football

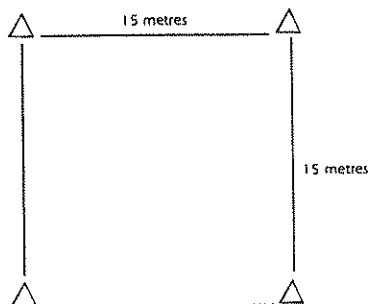

- One team is given the ball and attempts to complete a set of passes (up to 10, nominated by coach)
- Every set completed gains a point
- The opposing team attempts to intercept or knock the ball down, gaining possession when the ball hits the ground or is intercepted
- Player in possession can not move so his team mates must move around to support him and look for the pass
- Passes must be Rugby League style

BENEFITS OF GAME:

- Passing • Decision Making
- Space Awareness • Communication

Cut—

SPEED ATTACK

- SETTING:**
- Area up to full size field
 - 2 Equal teams of players
 - 2 Footballs

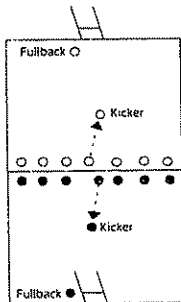

N.B. The ball must not be kicked into touch.

- Two opposing teams line up along halfway. Each team has a kicker and a fullback.
- On a given signal from the coach, the balls are tapped on the ground and passed to the teams kicker who kicks downfield, away from the fullback.
- When the fullback retrieves the ball, he must dive on the ball and wait until all of his team mates are onside before he plays the ball.
- The ball is then played and it must be touched by all players, before reaching halfway.
- The first team to place the ball on halfway scores a point
- Game can be played to a set time or a number of points.

BENEFITS OF GAME:

- Passing • Communication • Fitness

CHALLENGE

- SETTING:**
- Grid 25m x 35m
 - 10 players (2 teams of five)
 - 8 Markers • 1 Football • 5 Bump Pads

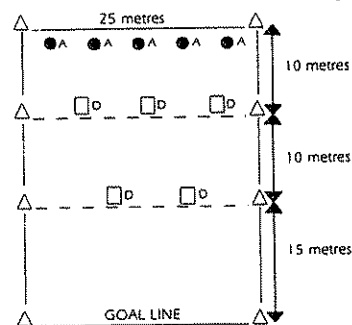

AIM - Five attacking players attempt to score a try against five defenders in two lines, 3 and 2 as per diagram.

- Defenders can only move laterally on their line
- Attackers must use attacking flair and support to first of all get past 3 defenders and then continue to beat the next line of 2 defenders. First 3 defenders can turn and chase when attackers pass their line.
- A tackle is effected by a two handed touch on attackers
- Teams change and alternate attack and defence.
- Points are awarded for tries, and deducted for negative plays that don't advance the attack.

BENEFITS OF GAME:

- Develop competition amongst players
- Communication • Support Play
- Develop Attack and Defence • Decision Making

LANES KICKING

- SETTING:**
- Grid 25m x 20m
 - 2 teams of players (4 attackers v 3 defenders)
 - 6 Markers • 1 Football

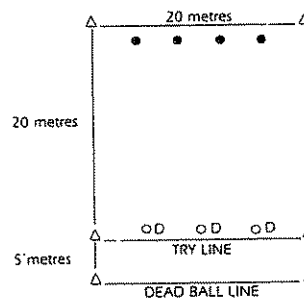

AIM - To score tries through kicks

- Attackers have 2 play the balls to score a try.
- Each play the ball must contain a kick (grubber, chip).
- Players can run from acting half back position or have one pass (Maximum).
- Defenders must return to try line after first tackle to commence second play.
- Competition by awarding a point for each success i.e. score a try to attackers, effect a tackle by defenders.

VARIATION

- Able to kick on either 1st or 2nd tackle i.e. run on the first, kick on the second (options)

BENEFITS OF GAME:

- Develop competition amongst players • Communication • Kicking Skills • Decision Making

SPEED TOUCH

- SETTING:**
- Grid 20m x 20m (approx. depending on players)
 - 2 Equal teams of players
 - 4 Markers • 1 Football

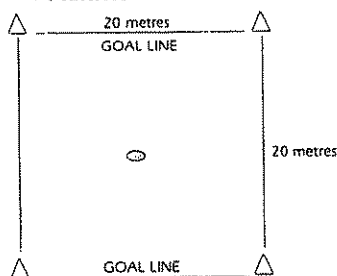

AIM - Team is to score against other team without being touched (one touch per team before hand-over)

- Teams line up on their own goal line to start game
- Ball is placed in middle of grid
- Teams run out and one picks up ball
- Touch can either be a two handed touch, or full tackle
- When the touch is made the ball is placed on the ground and both teams retire to their own goal line and then return to pick up the ball and continue game (hand-over) with a play the ball.
- The team that was attacking now goes on defence.
- Incorrect play the ball incurs a penalty which is a hand-over.
- Other penalties are also a hand-over

BENEFITS OF GAME:

- Defence • Passing Skills • Communication
- Decision Making • Fitness

LEAGUE SOCCER

- SETTING:**
- Grid 20m x 30m
 - 2 Equal teams of players
 - 12 Markers • 1 Football

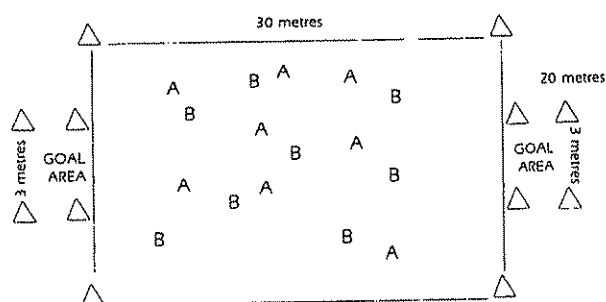

- The game is based on rules of soccer, using a Rugby League football
- Football not to be kicked above shoulder height
- No hands to touch ball (play the ball not the player)
- Goals scored into goal area (3 metres wide)
- Game can be played for a time limit, or nominated number of goals

BENEFITS OF GAME:

- Ball Control on ground & dribbling
- Fitness • Communication
- Team Work - co-operation between players

Cut —

KICK FAST BREAK

- SETTING:**
- Grid 32m x 15m
 - 2 Equal teams of players (A & B)
 - 8 Markers • 1 Football (more can be used)

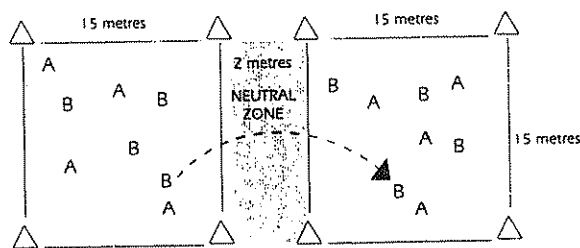

AIM - Players to kick football across the neutral zone to a team mate on the other side.

- Teams of players are divided and placed, half of each team is placed on either side of the neutral zone.
- One point is awarded for every successful kick caught.
- Opposition players attempt to knock down or intercept the football before it is caught.

VARIATION: Kick with non preferred foot
Catch with one arm

BENEFITS OF GAME:

- Kicking technique • Catching
- Communication • Positioning

LEAGUE HAND BALL

- SETTING:**
- Grid 15m x 10m (goal area 3 metres wide)
 - 2 Equal teams of players
 - 10 Markers • 1 Football

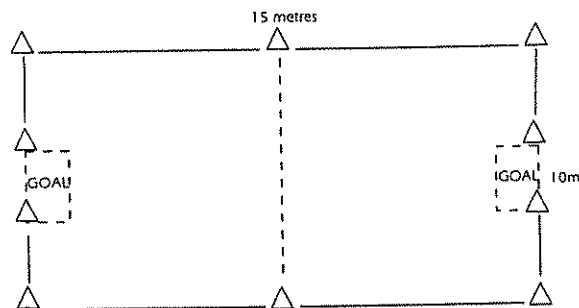

AIM - To pass the football between the opponents goal for a point

- Game commences with a kick-off
- Each team is allowed a goal keeper to guard the goal area, but no other players are allowed in this area
- Players may run with the football and pass in any direction
- Opposition players attempt to intercept a pass or knock the ball to the ground to force a change over
- After each point is scored the game recommences with a place kick by the non scoring team

BENEFITS OF GAME:

- Passing • Communication
- Decision Making • Space Awareness

TWO BALL LEAGUE

- SETTING:**
- Area 50m x 30m
 - 2 teams of equal numbers
 - 6 Markers • 2 Footballs

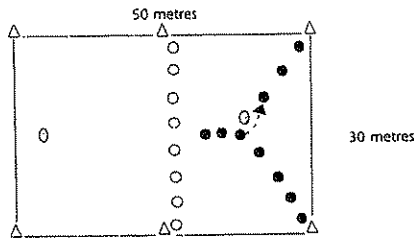

- Rules are identical to the Laws of Rugby League except: No tackling, no kicking, no scrums, two footballs used.
- The major difference in this game is that two footballs are used but only one at a time.
- The game commences as normal with one football while the other ball is placed at one end as displayed.
- The game continues until the coach blows the whistle.
- On this signal, the ball that has been used becomes 'dead' and it must be automatically dropped to the ground.
- The other ball becomes the 'live' ball and the first team to gain possession play on immediately toward their original line.
- There is no pause or stoppage! Teams have to react quickly
- The coach continues to blow his whistle at various times to change footballs.

BENEFITS OF GAME:

- Reforming positions • Reaction • Defence
- Communication • Attack - Support play

SCRAMBLE

- SETTING:**
- Grid 25m x 15m • 2 teams of equal numbers
 - 4 Markers • 1 Football

- Players from each team are given a number from 1 to 4.
- Team A - attackers, The coach calls out a number e.g. 4, those players with the number do the following:

Attackers (Team A)

- All must run to the attacking line and touch the ground with one hand. One of these players picks up the ball. They then run down the corridor attempting to score a try over the line, by staying inside the corridor.

Defenders (Team B)

- All must run to the try line, touch the ground and run up the corridor preventing Team A scoring a try by two hand tagging or tackling a player in possession.

Note

- Team A players may pass the ball between themselves but it must not be passed forward.
- Players from each side do not have to wait for all players in their team to get to the line to run. They may go at any time. As soon as players get tagged they return to their position and another number is called.
- 1 point is awarded for a try • Roles are reversed

BENEFITS OF GAME:

- Communication • Passing • Defence • Attack

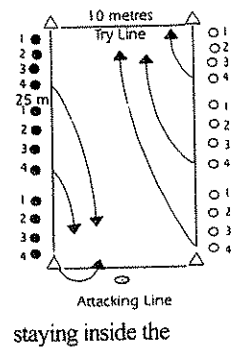

Cut—

GOALIE

- SETTING:**
- Grid 25m x 15m
 - Uneven teams e.g. (3 on 2) or (4 on 3)
 - 10 Markers • 1 Football

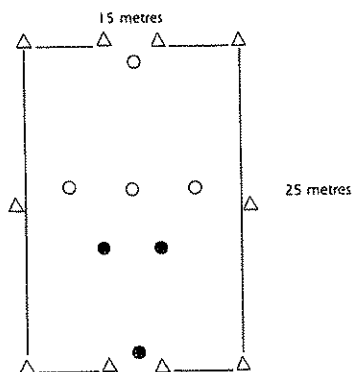

- Each team nominates a goal keeper before play starts.
 - Defending team goal keeper drops back to protect goal.
 - Attacking team passes football amongst themselves, passes can be along ground or Rugby League style and in any direction.
 - Goals are scored by attackers passing or grubber kicking football past goalkeeper and through goals.
 - Change over occurs by dropped ball or two handed touch.
- N.B.** - Defenders take turns as goal keeper

BATTLESHIPS

- SETTING:**
- Grid 10m x 10m
 - 2 Equal teams (Passes and Receivers)
 - 4 Markers • 8 Footballs

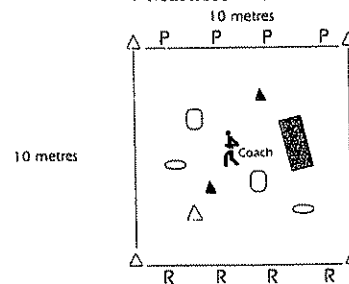

- Place objects inside grid e.g. tackle bag, hit shield, witches hat, marker, football etc.
- Passers line up outside grid, they each complete 4 passes to the right side and four passes to the left.
- 4 players at back of grid (receivers) to act as ball retrievers who pick up ball with two hands, then carry it back and place at passers feet, then return to retrieve the next ball.
- Passers attempt to hit objects, large objects (tackle bags) are removed from grid after being hit 3 times, medium objects (hit shields) removed after 2 hits and smaller objects removed after being hit once.
- Team eliminating most objects wins game.

VARIATION:

- Time limit on passes
- Vary the number of passes

SPEED TOUCH

- SETTING:**
- Grid 20m x 20m (approx. depending on players)
 - 2 Equal teams of players
 - 4 Markers • 1 Football

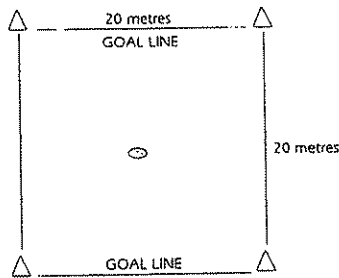

AIM - Team is to score against other team without being touched (one touch per team before hand-over)

- Teams line up on their own goal line to start game
- Ball is placed in middle of grid
- Teams run out and one picks up ball
- Touch can either be a two handed touch, or full tackle
- When the touch is made the ball is placed on the ground and both teams retire to their own goal line and then return to pick up the ball and continue game (hand-over) with a play the ball.
- The team that was attacking now goes on defence.
- Incorrect play the ball incurs a penalty which is a hand-over.
- Other penalties are also a hand-over

BENEFITS OF GAME:

- Defence • Passing Skills • Communication
- Decision Making • Fitness

LEAGUE SOCCER

- SETTING:**
- Grid 20m x 30m
 - 2 Equal teams of players
 - 12 Markers • 1 Football

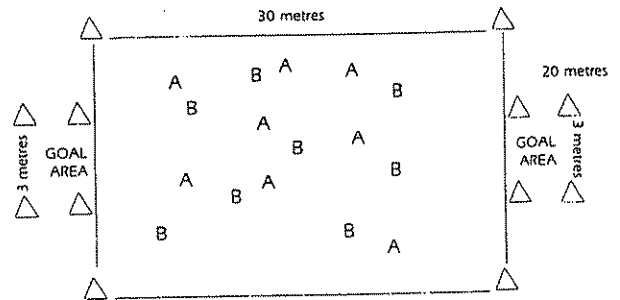

- The game is based on rules of soccer, using a Rugby League football
- Football not to be kicked above shoulder height
- No hands to touch ball (play the ball not the player)
- Goals scored into goal area (3 metres wide)
- Game can be played for a time limit, or nominated number of goals

BENEFITS OF GAME:

- Ball Control on ground & dribbling
- Fitness • Communication
- Team Work - co-operation between players

Cut —

KICK FAST BREAK

- SETTING:**
- Grid 32m x 15m
 - 2 Equal teams of players (A & B)
 - 8 Markers • 1 Football (more can be used)

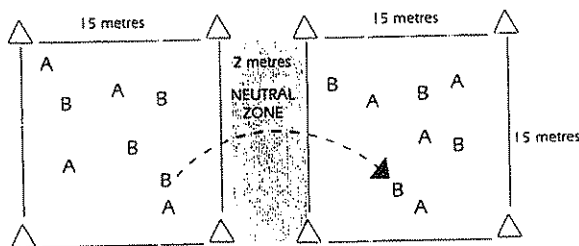

AIM - Players to kick football across the neutral zone to a team mate on the other side.

- Teams of players are divided and placed, half of each team is placed on either side of the neutral zone.
- One point is awarded for every successful kick caught.
- Opposition players attempt to knock down or intercept the football before it is caught.

VARIATION: Kick with non preferred foot
Catch with one arm

BENEFITS OF GAME:

- Kicking technique • Catching
- Communication • Positioning

LEAGUE HAND BALL

- SETTING:**
- Grid 15m x 10m (goal area 3 metres wide)
 - 2 Equal teams of players
 - 10 Markers • 1 Football

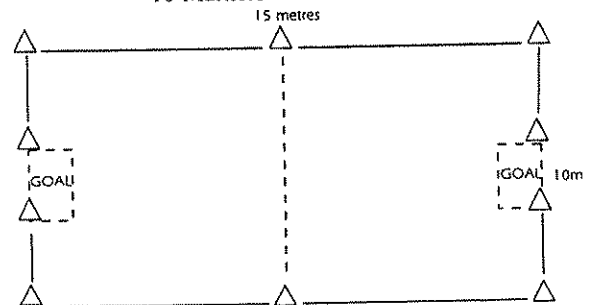

AIM - To pass the football between the opponents goal for a point

- Game commences with a kick-off
- Each team is allowed a goal keeper to guard the goal area, but no other players are allowed in this area
- Players may run with the football and pass in any direction
- Opposition players attempt to intercept a pass or knock the ball to the ground to force a change over
- After each point is scored the game recommences with a place kick by the non scoring team

BENEFITS OF GAME:

- Passing • Communication
- Decision Making • Space Awareness

BE KNOWLEDGEABLE OF THE GAME & NEVER STOP BEING A STUDENT OF THE GAME:

- Know the rules thoroughly
- Watch other successful teams play and try their moves
- Ask experienced coaches for help
- Read numerous coaching manuals
- View skill drill videos to get new ideas

Handbook COLLECTION

The first set of the Rugby League Coaching Magazine "Handbook Collection" is now complete. In your collection you should now have a 16 page "Drills Handbook", a 16 page "Games Handbook" and this "Mini and Mod Handbook". If you are missing any of these handbooks or require bulk copies please contact us today on 1800 18 14 14 or visit our Web Site.

The Rugby League Coaching Magazine's aim is to assist in the development and education of coaches and players at all levels. To aid in this aim the **Handbook Collection** has been produced to compliment the coaching magazine and we hope you find all products beneficial to your coaching.

32

Cut—

- The coach may be the only positive person of significance in that child's life.
- The impact words have on some children may be life-changing or very long-lasting. Be careful what you, as a coach say.

BE PROFESSIONAL:

The Rugby League coach represents:
 The image of the game to the public
 The club or school that he coaches
 The players
 The parents

- If a coach cannot avoid:
- publically criticising players when they make mistakes
 - 'bagging' or 'baiting' the referee
 - 'bagging' players on the other team
 - responding to the taunts of spectators from the other team

OR

- Thinking it's okay to allow you players to:
- constantly question the referee's decisions
 - use foul language
 - deliberately injure other players

THEN

Coaching is not for you!
 Coaches are powerful role models for children.
 The days of the loud-mouthed coach who condones thuggery are over!

RLCM Mini and Mod HANDBOOK

CONTENTS

- ② Conducting a Modified Footy Training Session
- ⑧ Tackling
- ⑭ Play-The-Ball and Pass from the Ground Drills
- ⑰ Ruck Play Drills
- ⑳ Game Situation Drill
- ㉑ The Pass Off the Ground
- ㉔ The Play-The-Ball
- ㉖ The Modern Junior Rugby League Coach

1

Conducting a **MODIFIED FOOTY TRAINING SESSIONS**

Enjoyment, participation, skill development, teamwork and competition, in that order, should always be the prime objectives when planning a training session for modified games players.

A session should take no longer than 60 minutes (shorter for mini players) and can be undertaken in as little as a 30 square metre area. The longer the session, the less effective it becomes, the larger the area, the less control the coach has over the players.

With simple planning, a session can progress from one activity to the next with very little disruption.

Include time for drink breaks during the session (2 to 3 if necessary). These can give the coach time to reset the field or look at the training schedule sheet.

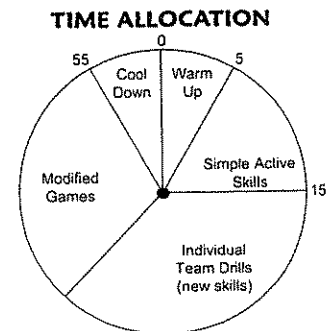

40

- make more mistakes and therefore 'punish' the team on the scoreboard (Criticism then becomes counter-productive, i.e. produces the opposite result to what was intended).

- lose respect for you as coach
- player loss of self-esteem (his most valuable possession)

People with high self-esteem are more likely to succeed in life.

BUT

People with low self-esteem will find things far more difficult

* Criticise the mistake - not the person

- Players look to you for approval - not condemnation
- Most parents hate to hear a coach 'bagging' their child.
- Coaches will quickly get offside with parents if they are publicly critical of their children.
- At the end of a match which the team has lost, be just as supportive as if the team won.
- Players will be upset enough without the coach making their day even more miserable.
- Always be positive and view mistakes and losses simply as opportunities to improve the skill level of the players and to eliminate weaknesses in team play.
- The best way to destroy a player's love for the game of Rugby League is to crush their spirit by criticising them constantly.
- Unless they move to another club or another coach they will likely give the game away rather than expose themselves to criticism each week.

30

Cut

WARM UP CIRCUIT

- Make the warm up as interesting as possible with a variety of gross motor activities.
- Clearly demonstrate what is required.
- Have the players run in pairs to encourage each other. (Try using a stop watch)

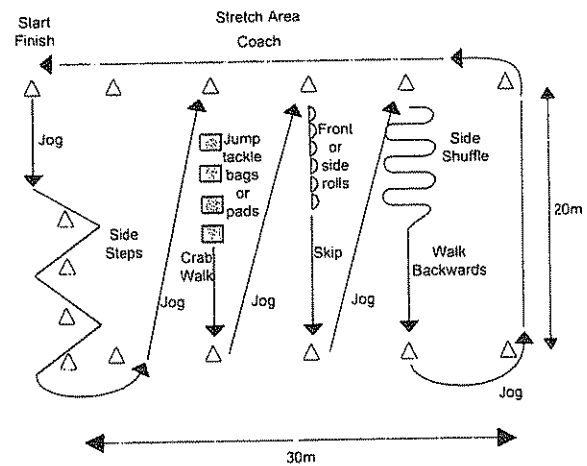

3

- There is nothing worse than for a parent to run their child to two training sessions through the week only to have their child play for 10 minutes on Saturday.
- Coaches philosophy on fairness can be severely tested in important matches when poorer-skilled players replace better players during a match.
- Every team have players of varying size, strength, skill, intellectual ability and temperament.
- It is unfair to have too high an expectation of any individual player.
- More should be expected of highly-skilled players.
- Less should be expected of less-skilled players.
- It is unfair to overuse a particular player just to win a match.
- It is unfair to leave less-skilled players out of any plays whatsoever.

BE SUPPORTIVE:

- Your players will make many mistakes such as knock-ons, missed tackles, forward passes, offside plays, etc.
- It is important that you assist players overcome these.
- However, you must encourage them to forget these mistakes and to do better next time.
- 'Bagging' a young player over a mistake will only increase the potential for that player to:
 - become discouraged
 - play nervously

RELAYS

- Group explanations and control are easier if all the players at one of the relay line.
- When explaining new drills, have all the players sitting down.
- Limit each line to no more than 4 players to maximise player involvement.
- Variations of skills that can be performed include:

Throwing the ball above the head and catching, picking up the ball, grubber kicking, play the ball, passing on the run.

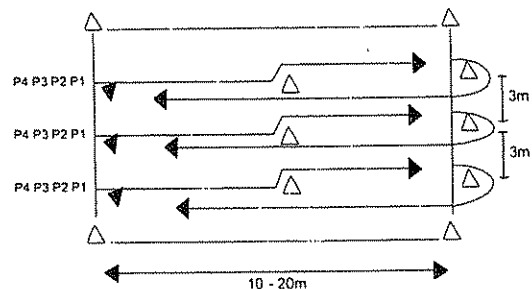

Coach stands to the side where he can see all the players.

29

- Mini-Leaguer training sessions should have a strong element of skill development and virtually no fitness training
- Older-Leaguer training sessions should maintain skill development but have an increasing element of fitness and endurance because of the bigger field to cover and the longer periods of playing time.

BE PREPARED:

Players should know their positions
 Players should know their roles (e.g. Capt./Organiser)
 Players should know team calls
 Players should know who is on the bench and when interchanges will take place
 Players should know when it's their turn to kick for goal
 Do not expect players to 'spread out' in a match if you haven't practiced it in training sessions.
 For younger players keep the game plan simple.
 Young players cannot remember complex moves. For example: very few 7-12 year-olds can spot a gap out wide and prepare to run for it. (Remember that children up to the age of about 10 have only about 30% of the width vision as adults - they tend to have 'tunnell' vision)

BE FAIR:

- Children have a strong sense of justice.
- The coach must not only be fair, but appear to be fair.
- Try to maximise the amount of time each player spends on the field.

28

GRIDS

- May be used for a variety of skills, such as handing – off, reverse passing and swerving. Players may run diagonals or around the square.
- Sample grid, below emphasises picking up and placing the ball.
- Use 4 footballs and start at both corners.
- Increase complexity by introducing runner from all four corners.

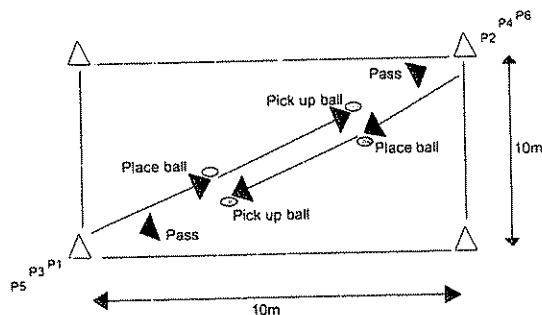

5

COMMUNICATING YOUR PHILOSOPHY:

- Tell your kids what you believe.
- Tell your parents what you believe.
- Coach and deal with your players in a manner consistent with your beliefs.

BE ORGANISED:

- have all your equipment ready to go e.g. individual water bottles,
- basket with kicking tee, nail clippers, tape, spare studs,
- Match Stats Sheet
- Video camera and tripod
- Manager well-briefed
- Trainer well-briefed
- Training sessions should be a mixture of skill drills and ballwork which closely simulate what the players will have to do in matches.
- Aim to teach at least one new skill and one new rule each week/fortnight and practise that skill/rule until it is mastered.
- Training sessions should be carried out with enthusiasm, with no spare time for players to get bored or start misbehaving.
- Training sessions should be 'fun' whereby players practise skills in games situations without realising it.
- Pre-match warm-up and stretching activities should be well-drilled and become a habit for the players to perform.

27

RLCM

BOOK 3 MINI & MOD

CIRCLE ACTIVITIES

- These are ideal for passing games.
- The coach can co-ordinate the skills from within the circle or by walking around the outside.

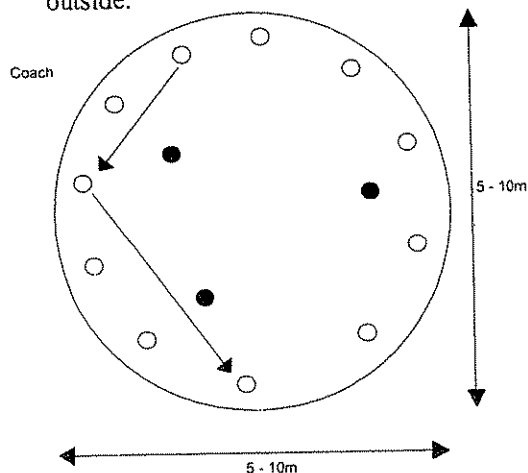

- Players try to intercept passes
- A player can not pass to the player standing closest next to him

6

Page 12

The Modern Junior Rugby League Coach

By Ray Howitt
ARL Level 2 Coach

- Must: Have a sound philosophy towards coaching Rugby League
- Must: Communicate that philosophy
- Must be: Organised and well-prepared
Fair
Supportive
Professional
- Must have: Knowledge of the game and continue to grow in knowledge

PHILOSOPHY: (What do I believe)

What is your motivation for coaching?

- Were you pressured into the job?
- Is coaching just another challenge?
- Do you have a vision of what you can achieve?
- Are you super-competitive?
- Are you a 'Winning is everything' coach?
- Are children mere tools for your experiments/ego/frustrations/anger?
- Is club loyalty important to you?
- Will you accept a mediocre group of players to coach or will you go out and 'poach' good players from other teams to strengthen your own team?
- Are you embarrassed when your team constantly loses?
- Do you find it difficult to say positive things about your players following a thrashing by the opposition?
- are you there because you want to help kids?

26

Cut

FIELD LAYOUTS FOR DRILLS, SKILLS & MODIFIED GAMES

Sample field layouts are shown on the following pages, with sample activities that illustrate that not only is a small field sufficient, but more manageable. Sizes will vary depending on the age of the players. If for example passing is involved, the coach would not expect a 7 year old to pass more than 3 metres. When possible, use field markings such as trylines or touchlines.

**RUGBY
LEAGUE
COACHING
MAGAZINE**

Since 1993

Visit our Website

www.rlcm.com.au

7

He then:

1. Bends his left leg and brings it up under his body. (Figure 1.)
2. Turns to a half sitting position, placing his right hand on the ground. (Figure 2)
3. Swings his right foot up and half stands, bringing the ball up off the ground. (Figure 3)
4. With his head forward for balance, places the ball on the ground in front of his left foot and pushes it back with the foot to the acting (dummy) half. (Figure 4)

(Young players should be encouraged to maintain control by using 2 hands when placing the ball.)

Keep in mind that the aim is to work toward a quick and smooth pass-the-ball.

THE ACTING – HALF BACK PASS

The pass from the ground should be dispatched in the fastest and most efficient manner possible. This is best accomplished by using the following method.

1. Keep eyes on ball as it is being collected and immediately adjust hands for passing.
2. Place the foot furthest from the receiver close to the ball and step with the other foot in the direction of the pass.
3. Sweep arms up through and extend them in the direction of pass. Eyes should be on target.

25

RLCM

BOOK 3 MINI & MOD

TACKLING FROM BEHIND

Key Coaching Points

- **Contact**
Shoulders should be under the buttocks with the head across the buttocks and the arms wrapped tightly around the thighs.
- **Leg Drive**
Defenders should dive towards the attacker to prevent him getting out of reach.
- **Landing**
After securing a tight grip, slide down the attacker's thighs securing the runner at the knees.

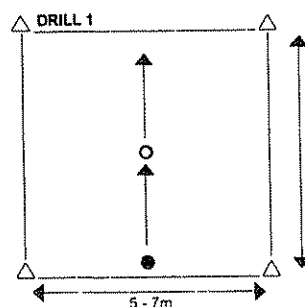

Both players crawl on knees in the same direction. Progress to standing, then walking and jogging in the same direction

8

Page 13

THE PLAY – THE – BALL

Even at the elite level, the rucks decide.

The ruck area in the modern game can be a deciding factor to the end result at all levels.

As one respected coach remarked, "It's the centre of the universe in Rugby League."

For the purpose of this article the ruck area will refer to the play-the-ball and the two acting halves in senior football, and the acting half back in modified league for the team with the ball.

Obviously the areas to develop in attack are:

1. the speed and quality of play-the-ball
2. the speed and accuracy of the acting half back's pass.

The coach should look to a play the ball method that ensures both control and minimum number of movements to fulfil the requirements of the movement.

Assume that the player tackled prefers to play-the-ball with his left foot. As the tackler releases him he rolls quickly on to his left hip.

Cut—

constantly practice and play ruck games so as to evaluate the skill of ruck play so that the first receiver is also able to move with the ball. Statistics will show that in a senior game there is upwards of 300 play the ball movements. Proportionally one can assume that there is approximately 200 in a junior game, 150 in a mod game and 110 in younger age groups. These figures indicate the importance of performing the play the ball correctly and efficiently.

RLCM - Handbook Collection

Bulk Orders for Clubs and Schools

"Our coaches have found your books so informative that they have grown in confidence and most of all have a better attitude and understanding of dealing with kids at a coaching level and believe they have improved their skills as a coach".

Robert Smythe
Mona Vale Rugby League Club

ENQUIRIES FREECALL

1800 18 14 14

23

RLCM BOOK 3 MINI & MOD

Tackling from Behind Continued

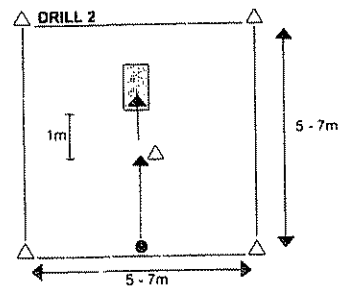

Defender must dive from before the marker to hit the bag at waist / buttock height.

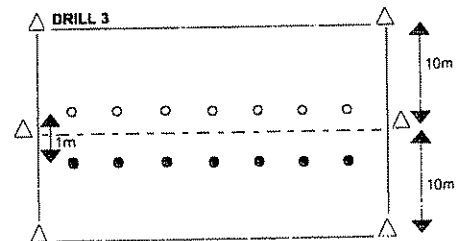

Two teams nominated black or red facing each other with evenly sized partners.

Coach calls either black or red. That side turns and runs towards their tryline, the other side chases and attempts to tackle to score.

9

FRONT ON FALLING BACK TACKLE

Key Coaching Points

• Technique

Same as side on tackle, except the head is placed to the side of the tacklers body (not across body).

Falling Back

- Use attacker's momentum to bring the attacker to the ground, falling with him to land on top of his legs.

(The "driving" tackle is recognised but is not considered appropriate for inclusion in a modified footy segment.)

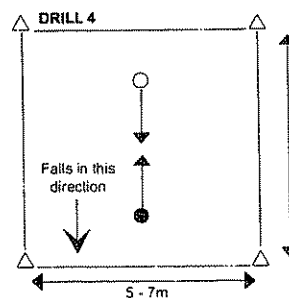

Start with Defender in kneeling position. Progress to Attacker walking and then jogging towards defender

10

Page 14

THE “PLAY THE BALL” and THE “2 PASS RULE”

Two areas of the modified game that raise a concern with many coaches regarding the coaching of the game and of players are (1) the play the ball and (2) the “two pass” rule.

A situation often encountered is where the play the ball is slow or clumsy and followed by a deep pass to a standing “pivot” (1st receiver) and then a further pass to a 2nd receiver who is standing and catches the ball before attempting to run. Often the opposition defence has claimed the 2nd receiver before he is able to go forward. In fact most coaches will drill their players to move up quickly as a defensive manoeuvre. This results in the team in possession going backwards, so much so that teams will often gain more ground in defence than in attack.

Coaches need to help players with a relatively quick and smooth play the ball. Coaches also need to show players how the 2nd receiver more ably handles this position. Coaches must address these situations as early as possible in young footballers (under 7’s). Coaches need to

Cut —

SIDE ON TACKLE

Key Coaching Points

- **Target Zone**
Lower than the hip and above the knee (the thigh)
- **Body Position**
Upper body slightly bent over, eyes raised and head tilted so as to be behind the attacker’s body, eyes focused on the contact point, arms spread, ready.
- **Contact**
Shoulders should make first contact with the contact point, followed by the arms wrapping around the body with a tight grip.
- **Follow through**
Drive with legs so as to land on top of the attacker.

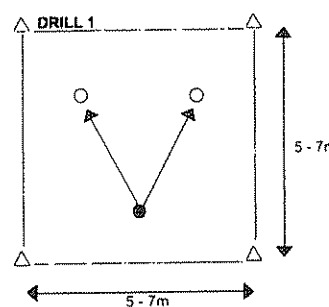

Both Attackers and defenders in kneeling position. Practice tackling in both sides.

11

THE PASS OFF THE GROUND (The Dummy/Ruck – Half Pass)

For 1st and 2nd receivers to have time, they must receive a snappy pass from the ruck-half.

Coaching Points:

1. Look at the positioning of the intended receiver to ascertain the distance of the pass.
2. Spread the feet and bend at the knees so as to get down over the ball. If passing to the right the left foot will be near the ball as it is played and right foot will be pointed towards the receiver. (The ball is between the feet.)
3. Hold the ball in two hands with fingers spread about the centre of the ball. The pass is from the ground and should be smooth and even.
4. Turn the head and upper body towards the receiver.
5. Pass from the ground without lifting the ball or standing up.
6. Follow through with the arms with the fingers directing the pass to the receiver.

Side on Tackle Continued

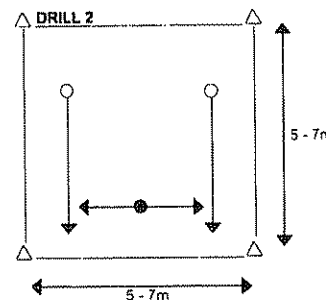

Defenders kneel on one knee, attackers walk passed. Progress to couched position.

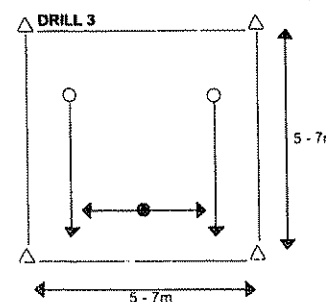

Attackers jog on coaches command. Defender tries to force attacker into touch using shoulders only and driving with the legs.

GAME SITUATION DRILL

P1 plays the ball to P2 who passes from the ground to P3 on the run.

P3 runs to draw the defender D1 and passes to P4 on the move.

P4 then takes the position of D1.

D1 goes to position of P1, P1 to P2, P2 to P3, P3 to P4

The drill is to be done on both sides of the play the ball.

The use of markers as a substitute defender or to indicate correct positioning may be necessary for the novice player.

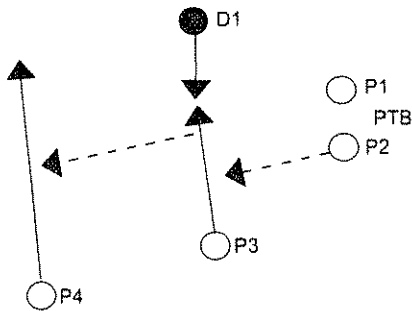

20

Cut—

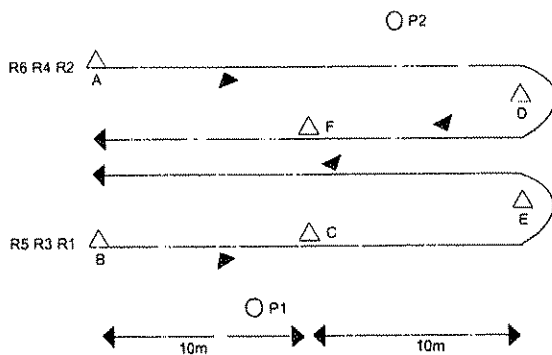

where they should pass to support players. Gradually eliminate the markers and introduce defending players under controlled conditions, simulating match situations.

All of the previously mentioned factors:-

- the play the ball
- the pass off the ground
- the movement and passing of 1st and 2nd receivers - go to make up the final execution of a 2nd receiver moving onto the ball. These are now placed in the "game practice" below.

19
RLCM

BOOK 3 MINI & MOD

Side on Tackle Continued

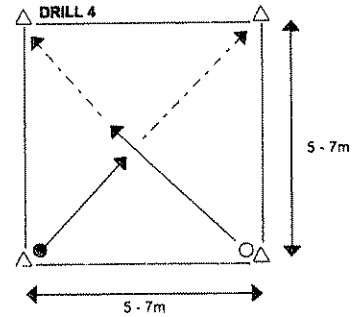

Defender attempts to tackle attacker as he runs towards opposite corner.

Attacker running in straight line tries to reach other corner.



**Football Club
Training and
Protective Equipment**

- Tackle Dummies • Hit Shields • Goal Post Pads
- Marker Cones & Domes • Medicine Balls

Telephone (07) 3256 6133
info@madisonsport.com.au

13

PLAY-THE-BALL AND PASS FROM THE GROUND DRILLS

1. Single file play the ball drill

Have 3 or 4 players form up in single file. The players perform the play the ball skill, commencing always from a position on the ground as if tackled. As the player plays the ball the next player being the acting-half, picks up the ball, runs a few metres and then rolls the ball out in front, dives on it and plays the ball and so on. Time: 5 mins.

2. Pass from the ground drill

Have players in groups of four, forming a grid about 3m x 3m. Players perform the pass from the ground and around the grid. Ensure the players' feet positions are correct.

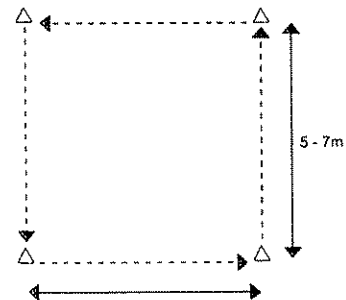

14
Page 16

2. Run and 2 Pass Drill

Time: 10 – 15 mins.

Have players form 2 lines of 3 players.

Commencing at markers A-B, R1 runs forward and receives a pass from P1 (pass to be from the ground), R1 continues to marker C where he passes to R2 running in support.

R2 runs and places the ball at the feet of P2.

R1 and R2 continue on to markers E-D and turn around.

R2 runs and receives a pass from P2 (pass to be from the ground), R2 continues to marker F and passes to R1 running in support.

R1 then runs and places the ball at the feet of P1.

R1 and R2 then run to the end of the lines swapping their starting positions.

R3 and R4 continue the drill and so on.

Initially the passing distance should be only one to two metres, as competence improves, gradually increase distance.

When coaching players on game positioning regarding ruck play, set out markers to indicate to players (a) where they should be (b) where they should run to and (c) approximate position from

18

3. Play the ball / pass from the ground relay

Have your players break into groups of 6 (as per diagram).

P1 starts on the ground, plays-the-ball to P2, who passes from the ground to P3.

P3 rolls the ball forward a short distance, dives on it and plays it to P4, who passes from the ground to P5.

P5 rolls the ball forward, dives on it and plays it to P6.

P6 picks up the ball then runs to the position of P1.

P1 goes to P2's position, P2 to P3 and so on. P6 rolls the ball forward, dives on it and the drill continues.

It is a good idea whenever a team is playing the ball at training to insist that the correct method of playing the ball is used and that it is always done from a position on the ground as if tackled. Also ensure that each time a pass is given from the acting half position that the correct method of passing from the ground is performed.

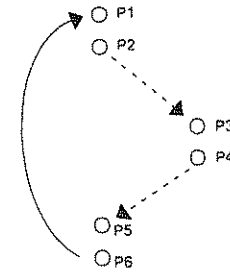

15

Cut —

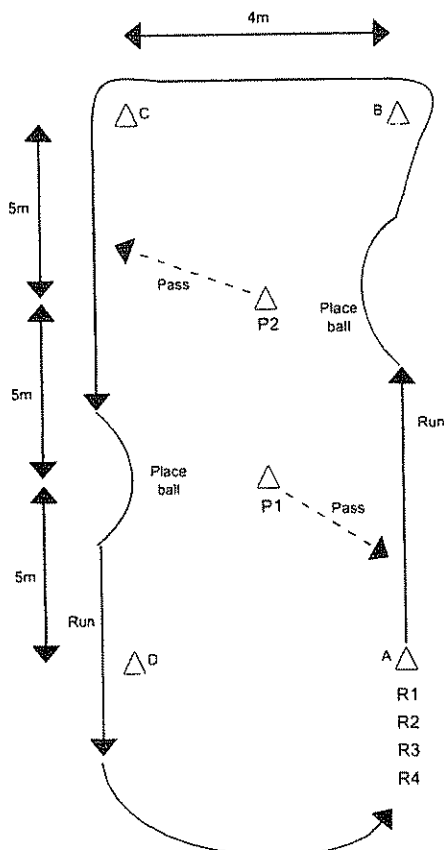

17

RLCM

BOOK 3 MINI & MOD

RUCK PLAY DRILLS

Time: 5 mins

1. Running onto the pass drill

Players should always be moving onto a ball even if the movement is minimal – a player moving with the ball attracts the attention of the opposition.

Have your players line up single file in groups of about four (4). Commencing at marker A, R1 runs forward and receives a pass from P1. (Pass to be off the ground).

R1 runs and places the ball at the feet of P2 and continues on to marker B and then through to marker C.

R1 then runs to receive a pass from P2 (pass to be off the ground), continues on and places the ball at the feet of P1 and moves through to marker D. R1 then joins the end of the receiver's line.

Receivers can run through the drill at suitable intervals. This will depend on the number of footballs available.

Initially the passing distance should be only one to two metres. As competence improves, gradually increase the distance. (Do drill in both directions, so that the ball is passed and received on both sides.)

16

Page 17

GRUBBER BUSTER

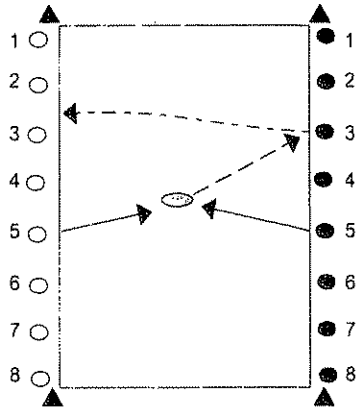

Divide players into 2 teams giving each player a number.

The coach calls out a number and the player from each team with that number runs forward and tries to gain possession of the football in order to return to his team. The successful player recovers the ball from the centre and passes it to any player in his team. That player then must immediately attempt to grubber kick the ball through the other team.

The player unsuccessful of gaining possession can pressure the kicker while his team must attempt to catch the ball by remaining standing on the line. The drill continues until all numbers have been called.

Cut—

KICK AND CHASE

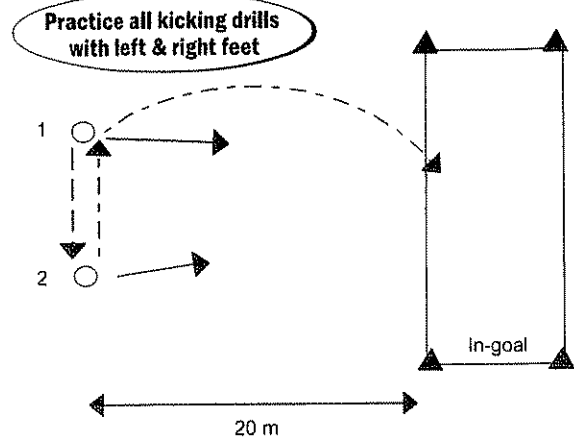

Aim To successfully put a kick into the in-goal area, beat a defender to the football and ground the ball to score a try.

Players 1 and 2 pass the ball back and forth. On the coaches command the ball carrier kicks (any nominated kick) to the try line and attempts to score a try by forcing the ball "in goal".

The player without the ball becomes the defender and attempts to tag the other player of "kill" the ball.

TARGET

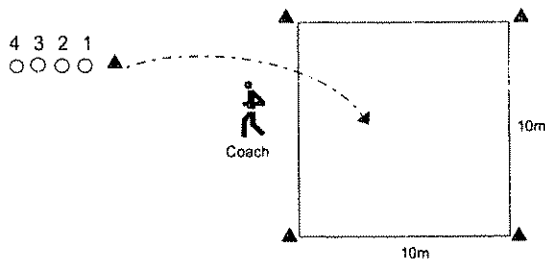

Aim To kick the football and have it land in the grid
Each player has a football

Grubber Kicks

Players must grubber kick the ball for it to land in the square, 10 metres from the kicking marker.

Punt Kick

The grid is taken further away - to 20 metres from the kicking marker. Players punt kick the ball and on the first bounce the ball must bounce in the square.

Drop / Chip Kick

As above for the punt kick, however the player / coach is placed between the kicker and the grid. The ball must gain elevation, clearing the coach / player to land in the square on the full.

Gear Required: Footballs, Witches Hats

J'OH'S ATTACK

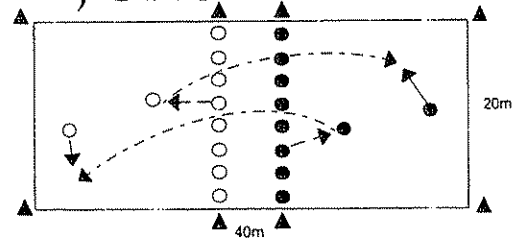

Divide players into two teams.

Two teams line up as indicated and oppose each other along the halfway zone. Each team has a kicker and a fullback and one football.

On the coach's command the balls are tapped on the ground and passed to the team's kicker.

The kicker then kicks the football down field away from the opposing fullback ensuring it lands in the opposition's half. When the ball has landed, all team members run to their line.

The fullback must retrieve the ball by diving on it and then waiting until all of his team are onside before he gets to his feet and joins his team on the line.

The ball is then passed to all players in a backline movement.

The first team to place the ball in the halfway zone wins.

The ball must not be kicked dead, all players except the fullback and kicker start on the line between the hats as indicated. The ball must not be passed forward or knocked on.

GRUBBER OR CHIP THROUGH

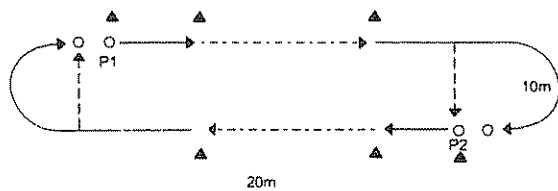

Aim Players are to complete a successful kick for themselves, regathering and then passing to support.

P1 runs, grubber kicks through the four witches hats (positioned above), regathers and passes to P2 who repeats back to P3 who continues the drill.

For variation the kick could be chip kick, a defender can be introduced or the kick could be for a partner.



ZENA JEWELLERS

Corporate Merchandising - watches, rings and tie pins

PHONE (02) 9579 1743

KICK TENNIS

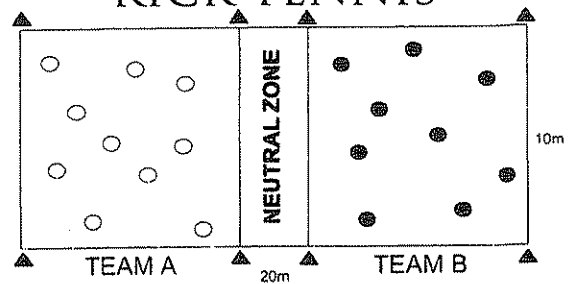

Each team is scattered through their own half as shown in the above diagram.

The ball is kicked by Team A into Team B's half. Their aim is to kick the ball making it land in Team B's half or force an error by a Team B player. If they succeed, a point is scored by Team A. If the ball is caught, no points are awarded. The ball must clear the neutral zone - otherwise possession is forfeited.

The ball is then kicked by Team B and the game continues in 'tennis' fashion. The first team to reach a predetermined score wins.

When the ball is kicked, it must cross the neutral zone at shoulder height or above.

Variations could be, adding two or more footballs. Instead of a scoring system, players making errors are eliminated from the game, the team that loses all its players first loses the game. The player catching the football must pass it to another player who then kicks the football.

Cut —

KICK AND CHASE

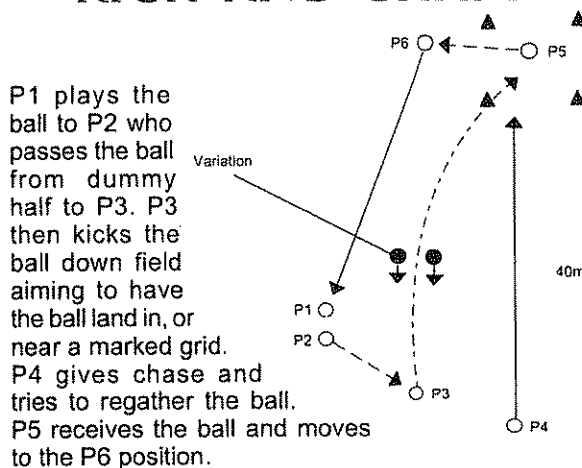

P1 plays the ball to P2 who passes the ball from dummy half to P3. P3 then kicks the ball down field aiming to have the ball land in, or near a marked grid. P4 gives chase and tries to regather the ball. P5 receives the ball and moves to the P6 position.

P6 who already has a second ball in hand runs to the play the ball and becomes P1 once P3 has kicked the ball and continues the drill, this ensures the drill continues without pauses.

Players rotate positions as the drill continues.

As a variation defenders can be added to put pressure on P3 as he kicks downfield.

Drill can be developed to imitate game play by including extra (P4) chase team and fullback (P5) runs a return.

KICK FOR SUPPORT

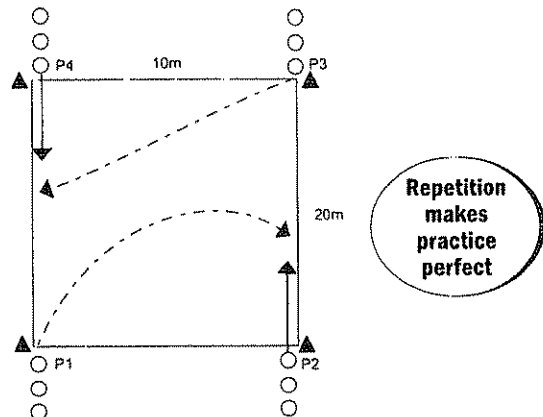

Aim Kicking for the support player who cleanly regathers the football.

P1 chip kicks for P2 who regathers on the full and runs through to offload to P3. P3 then grubber kicks for P4 who cleanly regathers the football from the ground and then runs through to offload to P1 who continues the drill.

Once P1 has chip kicked he moves to the end of the line in the P2 position, once P3 has kicked he moves to the end of the line in the P4 position.

As a variation another football can be added to speed the drill up.

CHANNEL KICK

Spend no longer than 10 minutes on each drill

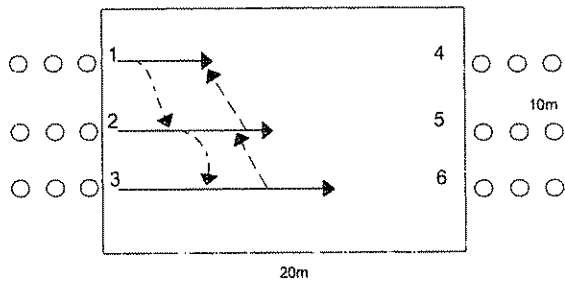

Aim Players either kick, catch or recover the football and then pass to support while on the run.

A grid is set up as in the above diagram.

Player 1 runs then grubber kicks to player 2.

Player 2 then chip kicks to player 3.

Player 3 runs then passes to player 2.

Player 2 runs then passes to player 1.

Player 4, 5 and 6 repeat drill. Perform this drill until all players have had an opportunity to grubber, chip and pass.

Cut—

KICK NETBALL

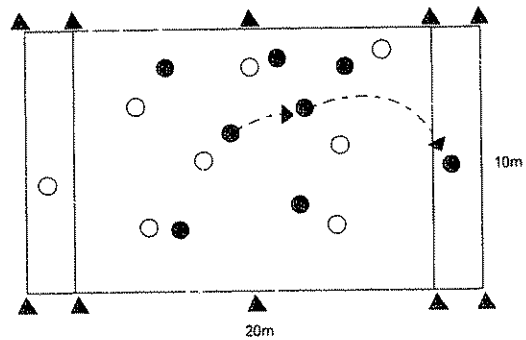

Aim For team mates to get the football to the player standing in the in-goal area by kicking the football.

Players are divided into two teams.

Each team kicks the ball between its own members. The ball can be kicked in any direction. The object of the game is to kick the ball to the player who is standing in the oppositions in-goal. Only one player is allowed in the in-goal. If the ball is dropped, the other team gains possession.

Players in possession of the ball must keep their back foot on the ground. Once the ball has been passed he is free to run anywhere in the field. (The game commences at one baseline. There are no set number of kicks needed, play continues if the ball is intercepted.)

GRID ISLAND

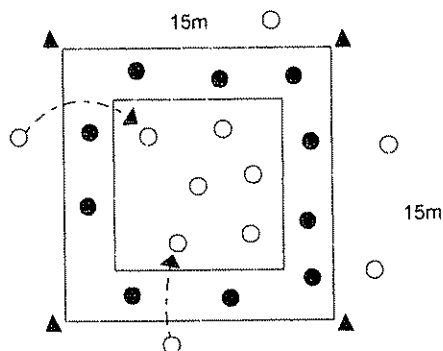

Aim Team A players to kick and pass the football to each other without it being intercepted or them being distracted by Team B players.

Divide players into 2 teams.

Two grids are set up as shown (1 small grid inside a large grid).

Team A passes/kicks while Team B are defenders attempting to intercept ball or distract Team A players.

Team A players are divided into 2 groups, one on the outside of the large grid and one on the inside of small grid.

GRID ISLAND con't

The outside Team A players start with 4 footballs, on coach's command the players attempt to kick or pass to their team mates in the inside grid. These players must catch the football on the full and must not go outside the small grid. They must then return the ball to the players on the outside of the grid.

Team A players are allowed to run around with the football but must hold the ball for any longer than five seconds. They may also pass the ball to another member of the team who is in a better position.

Team B players are to run around and attempt to intercept or distract team A players.

Once a ball has been dropped it is taken out of play and the drill continues with the remaining balls.

Vary the size of the grid to suit your team's age & ability.

KICKING
DRILLS

IMPORTANT

All Drills should be practiced using both
left and right feet

NUMBER CATCH

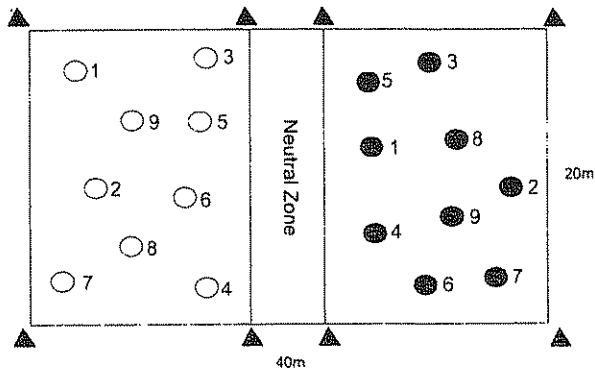

Aim For the attacking team to successfully kick across the neutral zone and for the defender to catch the football on the full.

Divide players into two teams. Each player is given a number.

Teams are scattered throughout their own half, as indicated above. The player in possession of the football calls out any number then immediately kicks its over the neutral zone and into the opposition's half. The player with the nominated number must catch the ball. No other player can attempt to catch the ball. Teams must vary their number calls each time they kick.

As a variation another football can be added.

DRIBBLE BALL

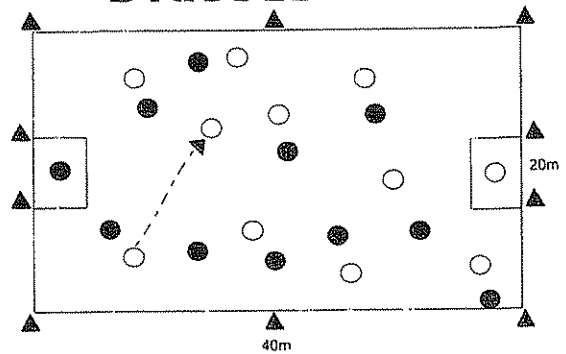

Aim To kick the football through the opposition's goal.

Players are divided into 2 teams.

Rules are similar to Soccer but a Rugby League football is used instead. The football is dribbled but players cannot touch the ball with their hands or arms with the exception of the two goal keepers.

NEWSLETTER	RLCM WEBSITE www.rlcm.com.au COACHING INFORMATION PHOTOS
FORUM	
CURRENT ISSUE	
COACH TALK	
LINKS	
GALLERY	

Cut —

FIND THE GAP

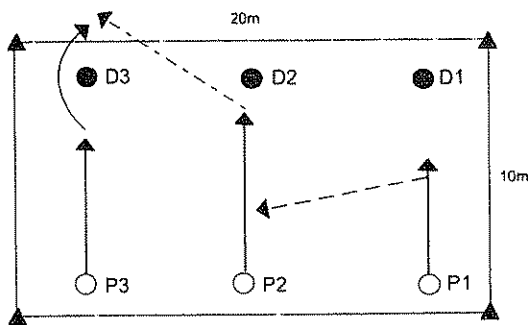

Aim To attack the defensive line, grubbering a kick through and the chaser regathers the football behind the line.

Grid is set up as shown in diagram above with players on a three on three situation.

P1 runs out, draws D1 and passes the ball to P2.

P2 runs towards D2 drawing him and then grubber kicking or chip kicking through the gap for P3.

P3 chases and regathers ball

Players must alternate playing positions each time. Drill should be performed from both right and left sides.

Vary the kick between P1, P2 and P3.

KICK GOLF

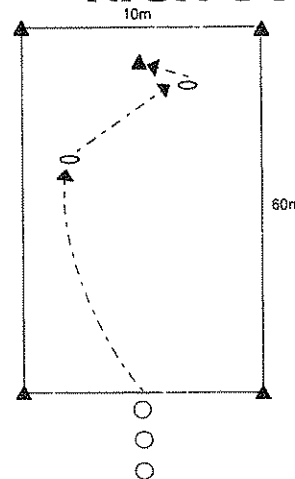

Use your imagination to design a fun kick golf course using any variation of kicks and distances

Players must try to hit the cone placed down field in the least amount of kicks.

The first kick is a punt kick downfield. The second kick is a grubber kick from where the ball has stopped towards the cone. The third kick should be in close enough range for a short stab kick or dribble kick for the ball to hit the cone.

Players keep kicking until they have hit the cone.

Players may need to add another grubber if kicks have gone off target.

Defence Nomination

Setting: Six attackers and five defenders. Each attacker has a hit pad, attackers in a line 5m away from the defenders.

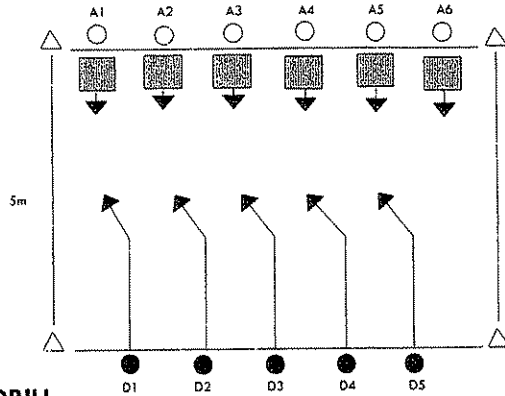

DRILL

- Coach call left or right and the defenders move up in that direction, nominating by name the attacker they will engage.
- Players engage the pad then move back changing place with another defender on the way back.
- Emphasis nomination amongst defenders.
- On returning emphasise communication amongst defenders.

Reaction Drill

Setting: Six lines of players opposite six tackle bags.

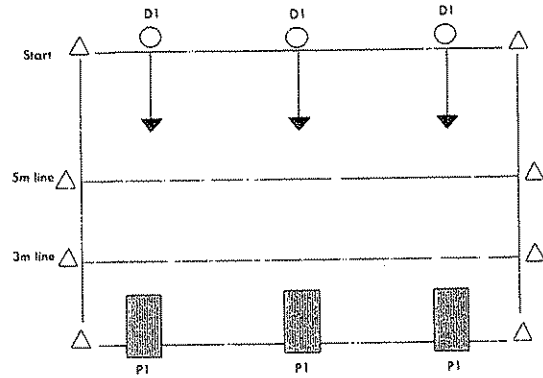

DRILL

- Player P1 holds bag up in front. He moves bag left or right when the tackler D1 reaches the 5 metre mark.

VARIATION

- Reduce distance ie 5 metres to 3 metres etc

Cut—

Situational Defence

(d) Against Extra Man

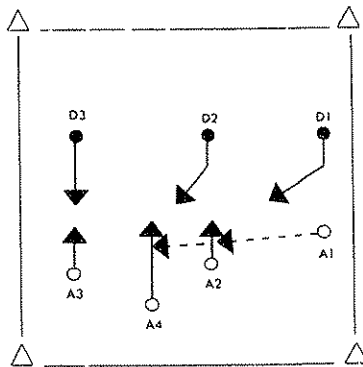

7 players - 4 attackers and 3 defenders

DRILL

- A1 passes to A2
- D2 and D3 move up
- A2 passes to A4
- D2 must move up and out
- D1 (or inside man) takes A2

Situational Defence Drills

Setting Next 4 Drills:

Small groups of players work in 10m x 10m grids - The defence's role, after the ball has passed his opposite, is to take the inside position on the next, outside attacker (this can not occur under a wedging system)

(a) Against Run Around

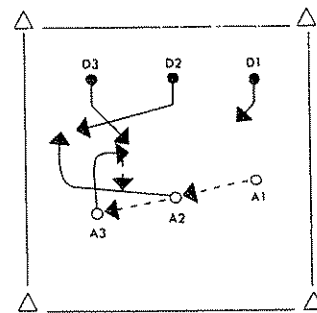

6 players - 3 attackers and 3 defenders

DRILL

- A2 around A3
- D3 takes A3
- D2 follows A2
- D1 fills in

ALTERNATIVE

- A2 around A3
- D2 communicates to D3 to take out A2
- D2 takes A3
- D1 fills in

Also use A1 around A3

Clockwise Tackling

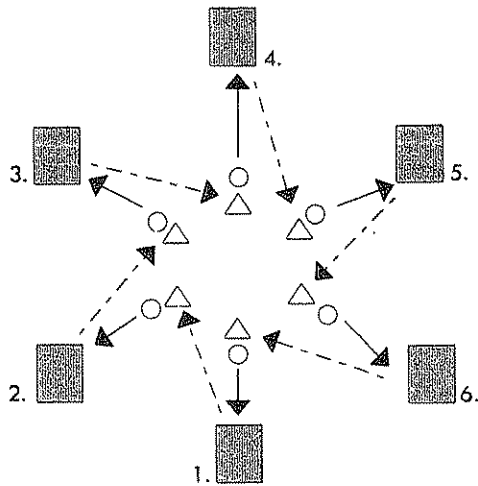

Tacklers position themselves in the centre of the drill, opposite a tackle bag. (As indicated)

Each of the players perform a tackle on the bag in front of them.

Players then run backwards to the centre of the drill, shuffling clockwise to position themselves in line with the next tackle bag, where they make the next tackle. The drill continues until all bags have been tackled.

Sprint & Slide

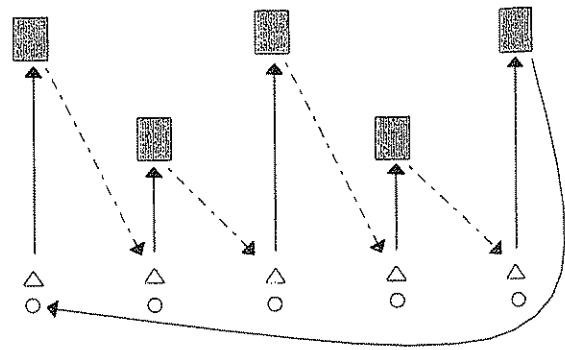

Players are lined up as above. Two tackle bags are positioned 10 metres from two players, whilst three bags are 15 - 20 metres from the other three players.

All players must sprint to the tackle bags and run backwards, shuffling across to the marker. Sprint distances obviously vary in length between 10 metres (short) and 15 - 20 metres (long).

Cut —

One on One

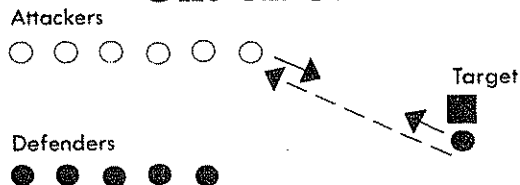

Divide players into two lines 6 metres apart, nominate one line as attackers and the other defenders, place a target (old T-shirt) midway between the lines.

The first defender comes forward with the ball and stands over the target. The defender passes the ball to the first attacker who must now score a try by placing the ball on the target.

The defender must tackle the attacker to stop the try being scored. The coach must emphasise that the defender must make and maintain solid upper body contact with the attacker. In all cases the defender must try to wrap up the ball and try to roll the attacker on his back to slow down the play the ball. The drill can be modified by changing the starting location of the defenders and attackers.

- The defender gains confidence by being in control of the drill, ie. the attacker must wait until the defender is ready and passes him the ball.
- The defenders quickly learn that they must move forward off their line to successfully defend the target.

Numbers Tackling

Divide your team into two equal groups, generally forwards and backs. One group holds the tackle bags or pads, the other group form up in a circle inside and facing the bags. The bag that they are facing is their **number 0 bag**. In this diagram we are showing how the circle looks to tackler number 1.

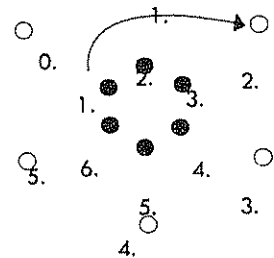

Coaches Command
"2 Right"

The coach calls commands such as "1 right", the players all have to move one bag to their right and tackle that bag. Then they move directly back and that bag then becomes their **new 0 bag**. The coach may then call "2 left" and the players move two bags to the left and make the tackle. Then move directly back with the bag tackled their **new 0 bag**.

Players must remember that once they move directly back, the bag just tackled becomes their new number 0 bag. It changes with each tackle. The players keep tackling until one or more players gets it wrong, they then pay a penalty (20 metre sprint) and they change roles with bag holders.

The Postman

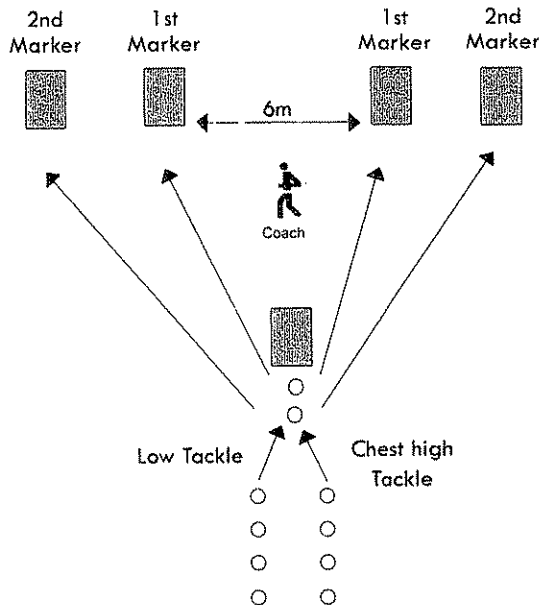

Players perform double tackle on front bag.

The coach rolls a ball to either the left or right markers. The players then chase and tackle the designated tackle bag, opposite the position of the football.

Flop

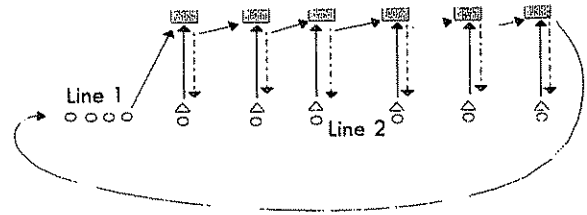

Tackler No.1 hits the bag low, whilst tackler No.2 is the second player and hits the bag chest high.

Players from line 1 will tackle 6 bags, whilst players from Line 2 will only tackle chest high on the allocated bag directly in front of them.

Cut---

Double Zone Tag

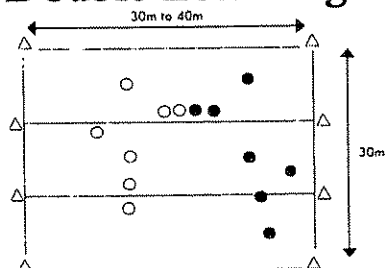

Aim: Defensive adjustment and communication attacking development of space creation.

Equipment: 8 markers (2 colours), 1 football, 12 to 16 players, tag belts if available.

Set Up: Playing area (using cross field markings) 30 metres wide by 30-40 metres long. Markers identifying "centre" or "double zone" area.

Drill

- Small sided game with rules as set by coach ie number of passes, allowable kicks etc.
- Outside thirds of field player 'tagged' by single player.
- 'Centre' third is the 'double-zone' where attacker must be tagged by two players (or both flags removed).
- Scoring can be adjusted ie 3 points between 'double zone' markers, 1 point outside thirds.

RLCM

BOOK 5 DEFENCE

Shut Down

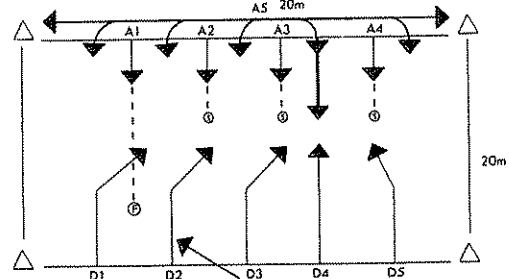

Aim: To develop vision and decision making skills of "middle" defensive players.

Equipment: 4 markers, 1 football, 9 to 15 players

Set Up: Set grid 20m x 10m. Place players at each end of grid with defenders having one extra.

Drill

- One attacker(A5) jogs behind line carrying football
- On coaches signal (or players choice), he enters attack line and runs STRAIGHT.
- Other attackers move up straight in support
- Defenders must call BALL CARRIER with TWO players contacting ball carrier.
- Defenders D1 to D5 (after shutting down ball) must next shut down CLOSEST support.
- The FREE player (F) is shut down by cover defender.

Page 24

Last 15 Defence Drill

Setting: Seven attackers on four defenders, grid 40m x 20m

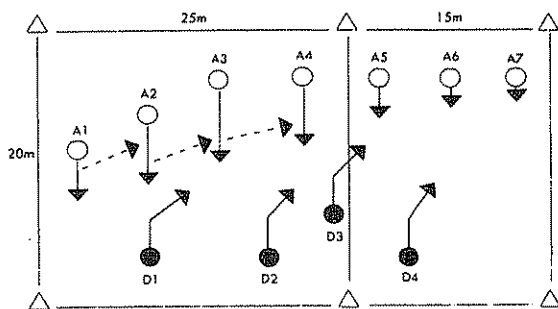

DRILL

- Attackers attempt to score within the last 15m width of the field.
- Defence must show the edge to the attackers
- Last two defenders should work to shutdown the last four attackers on the edge.
- The remaining two defenders should work in cover to ensure no inside balls are successful

React & Defend

Setting: Three attackers (A) on three defenders (D), grid 15m x 15m

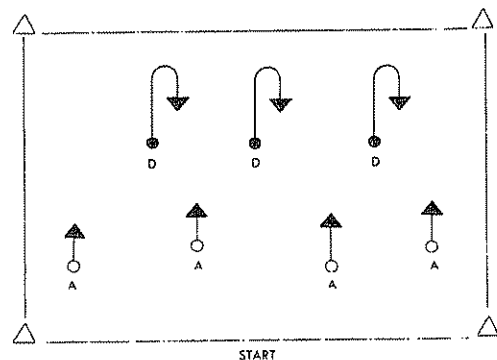

DRILL

- Defenders jog down the grid
- Followed by attackers about 5m behind
- On coach's call defence turns and adjusts to the attack

Advance to multi tackle 3 on 3

Commence with 4D x 3A, 3D x 3A, 2D v 3A

Cut —

Situational Defence

(b) Against Reverse Pass (see run around)

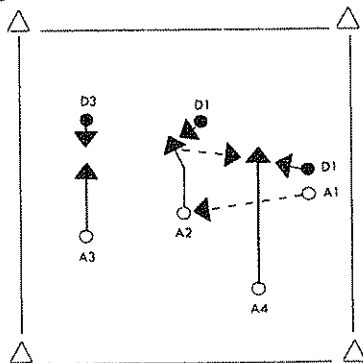

7 players - 4 attackers and 3 defenders

DRILL

- A1 passes to A2
- A2 moves across field
- A2 REVERSES to A4
- D1 fills in

ALTERNATIVE

- A1 passes to A2 onto A3
- A2 around A3
- A3 REVERSES to A4
- D3 stays with A2 (or A3)
- D3 takes A3
- D1 fills in on A4

Situational Defence

(c) Against Scissor (angle)

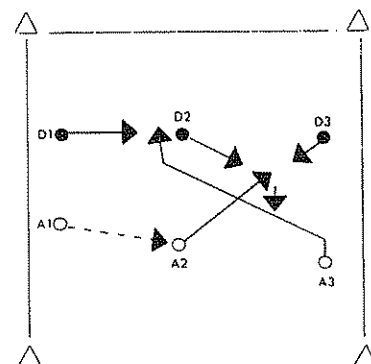

6 players - 3 attackers and 3 defenders

DRILL

- A1 passes to A2
- Attacker (A2) drags D2 across toward D3
- Attacker (A3) moves inside A2 when A2 commences to draw D3
- A3 is taken by the Cover D1 or D3

MARKER DEFENCE FOUR ON FOUR

Setting: - Channel 10 x 20m, 8 players,
4 players are defenders, 4 are attackers.

- Play the ball as in previous drills
- Introduce D4
- 'A' players can use all options in attack.
- Tight spot defenders must move forward to the advantage line and nominate in defence.

EMPHASISE: Communication, nomination, one marker holds and one chases, chase must be over the advantage line.

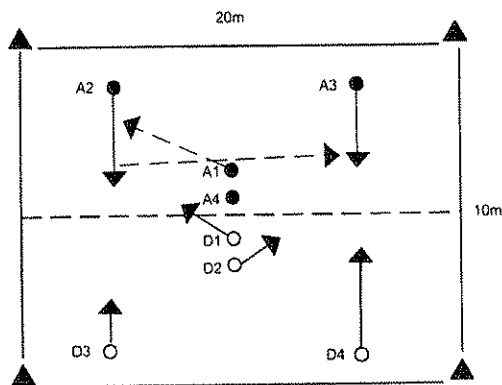

Cut—

AGILITY POLES

- Coach stands 5m in front of players holding pole.
- As players run towards the pole the coach leans it either to the left or right.
- Player then swerves to the opposite side of pole and runs around coach.

PROGRESSION

- Add a second pole wide of the first
- P1 runs to the side the pole is leant
- P1 then passes a flat pass to P2 who must swerve to the left or right of his opposite pole.

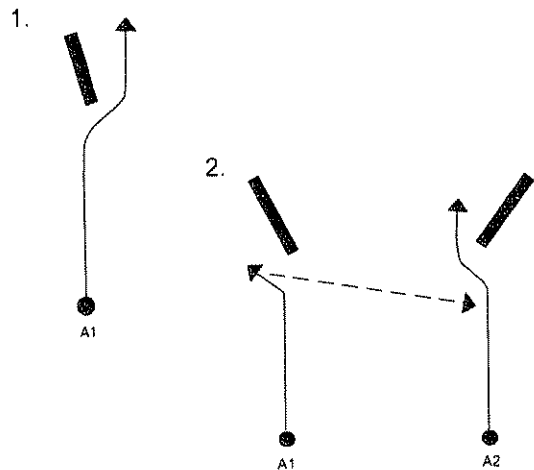

MARKER DEFENCE FOUR ON TWO

Setting: - Channel 10 x 20m, 6 players,
2 players are defenders, 4 are attackers.

- Play the ball occurs in centre track
- The ball is returned to the centre after each ruck.
- The marker must chase to the receiver while the other holds to protect the middle.
- Rotate roles
- Attackers can vary their width and the dummy half can also run to challenge the middle

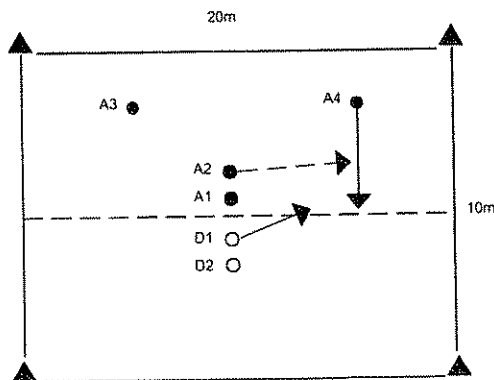

RLCM BOOK 6 DRILLS

ARROWHEAD

Setting: - Two equal lines of players aligned at right angles

- Team 1 commences the drill, running straight.
- Team one commences passing the ball at speed along their line.
- After releasing the ball each player runs backwards to their starting position.
- Player 1E off loads to player A in team 2.
- Team 2 then speed passes, following the same procedure as Team 1.

Note

- Player 1E holds the position of 2A waiting for the next run, likewise player @e holds the original position of 1A.

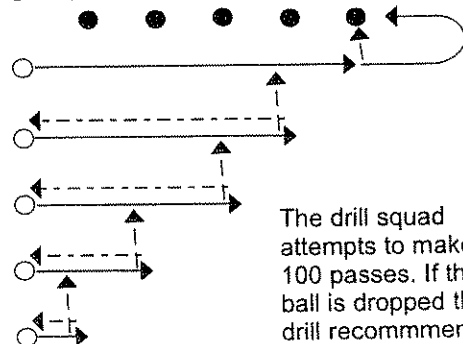

The drill squad attempts to make 100 passes. If the ball is dropped the drill recommences.

SMOTHER DRILL

Setting: - Players working in pairs one carrying a hit pad, 5m apart.

- Object is to cover the ball, i.e. pin bump pad to the ATTACKER.
- Players in pairs, opposite each other and 5 metres distant. Walking Pace.
- Object is for tackler to cover the ball and or pin the arms of the ball carrier.
- Defender slightly off-centre of the attacker.
- The front section of the tackler's shoulder makes contact with the attacker's chest region, shoulders and arms attempting to cover the ball and or pin the arms of the ball carrier.

Variation - Increase pace/and or approved distance.
- Remove pad and add the ball to attack

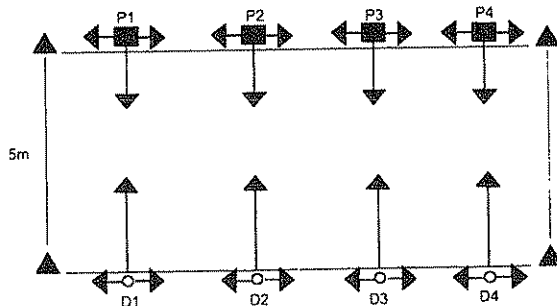

Cut —

3 ON 2 (A)

Setting: - Grid 10 x 10m,
2 players are defenders, 3 are attackers.

- Players line up behind cones in three columns.
- On coaches command two nominated players **sprint** our around opposite cones and then become defenders.
- Next two players fill in the attacking line.
- The attacking line then attempts to beat the defenders with a 3 on 2 situation.

EMPHASISE: Communication (attack and defence), drawing the man, no silly passes, start slow

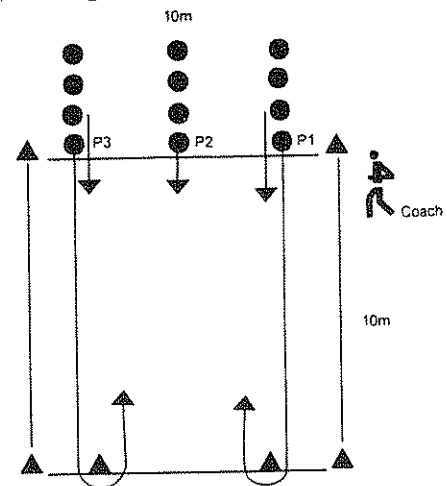

DEFEND TWO ON THREE

Setting: - Players in a 15 x 10 metre grid
- Three defenders and four attackers

- A1 and A2 must start within the 5m channel
- D1 will start 5m from A1 and also within the 5m channel, while D2 and D3 will start 10m away
- A1 must pass to A2 before A2 is allowed to leave the 5m channel
- D1 can move as quickly as he wants, however D2 and D3 can only move once D1 has moved
- the object is to stop the A's from scoring

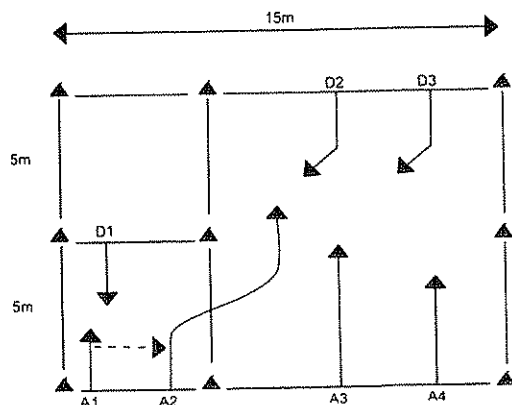

ROUND ROBIN PLAY THE BALL

- P1 who is positioned on the ground, rises to his feet and plays the ball to P2 who is directly behind him (acting half back).
- P2 passes left to P3 who falls to the ground and raises to his feet to play the ball to P4.
- P4 passes right to P5 who falls to the ground and then raises to his feet to play the ball to P6
- P6 passes left to P7 who falls to the ground and then raises to his feet to play the ball to P8.
- P8 runs to the position held by P1 initially.
- Each player, having completed his role moves to the position taken up by the next player in the drill.
- The drill is performed until P1 is back in his original position.

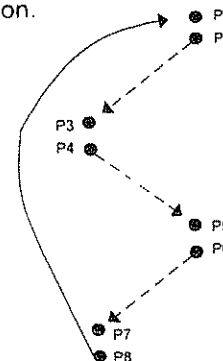

KICK AND PASS

Setting: - Grid 20m x 20m
 - 2 equal teams of players
 - 1 football

- One team is given the ball and attempts to keep possession for up to 10 passes or kicks.
- Every set completed gains a point
- The opposing team attempts to intercept or knock the ball down, gaining possession when it interrupts the other teams set.
- Player in possession may move around grid looking for best option.

Emphasise: One handed pass, fending and passing, passing under pressure, grubber kicks, chip kicks.

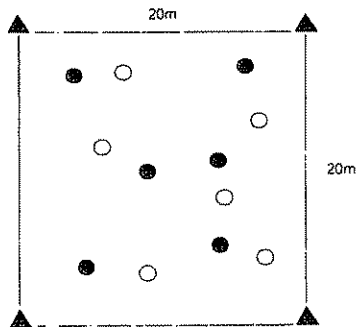

MARKER DEFENCE FOUR ON THREE

Setting: - Channel 10 x 20m, 7 players,
 3 players are defenders, 4 are attackers.

- Play the ball as in four on two
- Include D3, no wraps or reverse passes for attack but players can use inside balls and dummy half runs to challenge the holding marker
- Forces D2 and D3 to adjust to A2 and A3 while D1 controls the the middle.

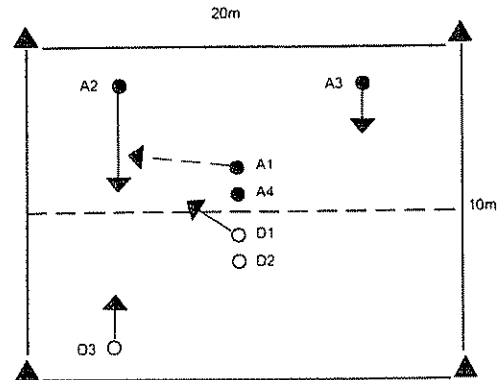

Cut—

ROTATION

Setting: - Players form two circles
 - Two players stand inside circles

- Players in the inside circle run one way whilst players in the outside circle run in the opposite direction.
- Two players in the middle make a pass:
 - To the players in the outside circle
 - Alternately to the inside and outside circle
 - To players in the outside circle with players in the inside circle attempting to knock down the passes

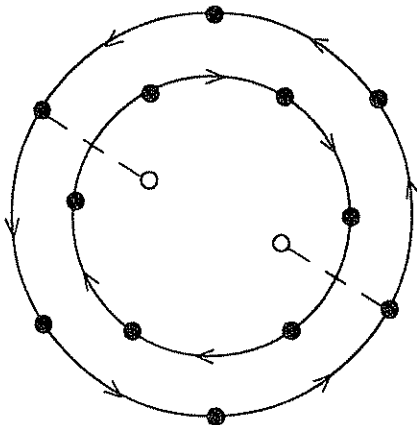

RLCM

BOOK 6 DRILLS

NOMINATION & NUMBERING

Setting: - Six attackers and five defenders, five of the attackers will hold hit pads whilst the sixth has a football.
 - Players spread out opposite each other in two lines about 10 metres apart.

- Coach stands behind the defensive line where they cannot see him.
- He directs the sideways movement of all the attacking players except A1, with the ball, either left or right by pointing.
- A1 moves at random behind the attacking line.
- When the coach puts his hand straight up in the air A1 must run forward through the gap in front of him, with the rest of the attacking line moving forward.
- Defence must adjust to nominate and eliminate all players closest to the ball, thus leaving one attacker on the edge free.
- Defence must nominate, ball carrier, runner, etc or call by name.

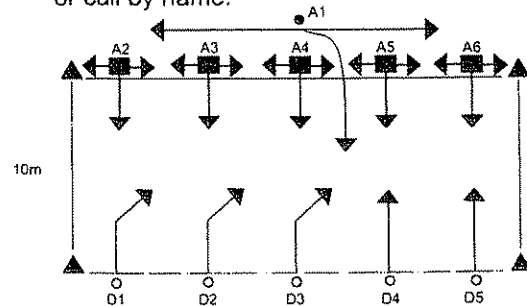

Page 28

3 ON 2 (B)

Setting: - Grid 10 x 10m,
2 players are defenders, 3 are attackers.

- Players line up behind cones in columns of three as attackers and defenders at opposite ends of the grid
- As attacking players move, coach commands one defender to stay out (nominate by name or number)
- The attacking line then attempts to beat the defenders with a 3 on 2 situation.

EMPHASISE: Communication (attack and defence), decision making, drawing the man, no silly passes, start slow

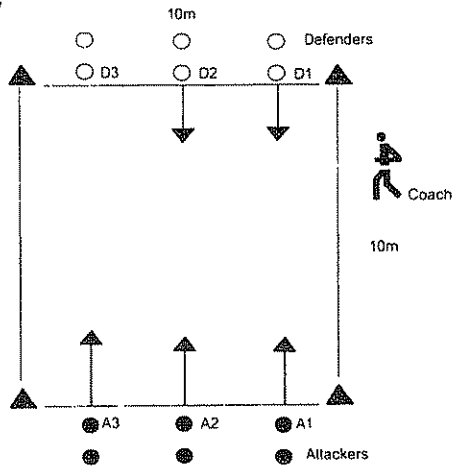

FACE-UP DEFENCE

Setting: - Corridor 20 x 15m, 4 markers, 12 players, 1 football

- 5 defenders are placed on the base line.
- 7 attacking players are grouped at the opposite end of the grid.
- The coach kicks the football to the A players.
- On A players gathering the ball the defenders move forward to prevent A scoring.

Progression: - A & D start with coaches call
- D move down the grid in formation A follows approx. 10m behind
- On coaches call, D turns and defends against A who attempts to score.

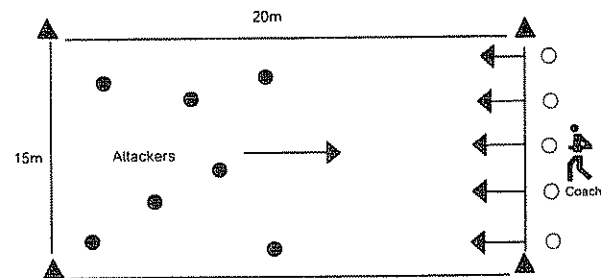

Cut

SQUARE DRILL

Setting: - Grid 7m x 7m

- P1 plays the ball to P2 who passes to P3
- P3 drops to the ground, regains his feet quickly and plays the ball to P1 who has taken his position behind P3, having run in a straight line to become acting half back.
- P1 then passes the ball to P4 who repeats the activity of P3, who now assumes the role of acting half back.
- This procedure is repeated for a period of time.
- The drill may be used competitively by allocating one point for each play the ball performed correctly. Three or four grids may be used competitively for further enjoyment.

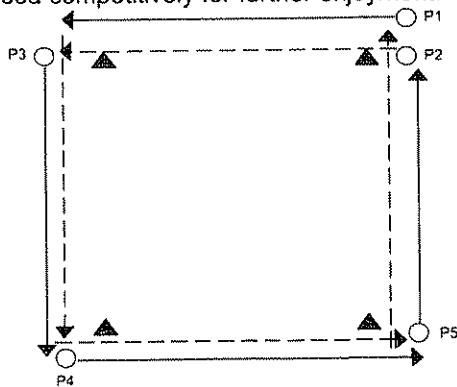

RLCM

BOOK 6 DRILLS

ROLL/PLAY THE BALL DRILL

Setting - Players form two teams 15m apart opposite each other.

On coaches command

- P1 from the Blue Team rolls the ball along the ground towards a member of the Gold Team.
- Player B who falls on the ball securely, plays the ball correctly to Player A. Each of the other members of the Gold Team form a backline; the ball is passed from player A to C, D, E, then F.
- Player F, upon reaching the marker, rolls the ball towards any member of the Blue Team.
- Once retrieved, the ball is played correctly with another member of the team moving into acting halfback.
- All other players position themselves in a backline formation and continue the drill along the same lines as the Gold Team.

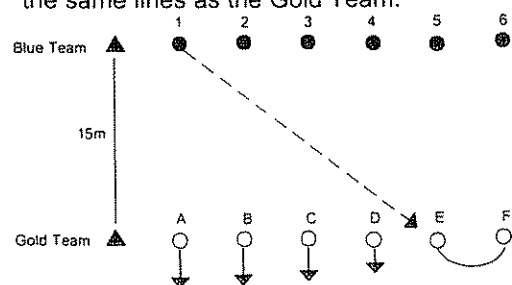

Page 29



RUGBY LEAGUE COACHING MAGAZINE
DRILLS HANDBOOK COLLECTION
COACH TALK YEARBOOK
COACHING KIDS - ONE COACH'S PHILOSOPHY

It may make the difference!

www.rlcm.com.au

Cut—



RUGBY LEAGUE COACHING MAGAZINE
DRILLS HANDBOOK COLLECTION
COACH TALK YEARBOOK
COACHING KIDS - ONE COACH'S PHILOSOPHY

It may make the difference!

www.rlcm.com.au

RLCM

RUGBY LEAGUE COACHING MAGAZINE

Since 1993

Assisting in the education and development
of football players and coaches at all levels

Drills No.1
Handbook
Can your team do without it???

RLCM
www.rlcm.com.au

RUGBY LEAGUE COACHING MAGAZINE

Since 1993

Assisting in the education and development
of football players and coaches at all levels

Games No.2
Handbook

RLCM
www.rlcm.com.au

Page 30

CATCH & PASS DRILLS

Catch and Pass Drills

(1) STANDING PASS

Standing Pass Coaching Points

- Hold football with two hands, even grip around the middle of ball with thumbs on top and fingers evenly spread around the bottom half of the football
- Start the pass from the hip
- Point the closest foot to the receiver
- Swing arms down and through across the body
- Release ball when in line with the target
- Transfer weight from outside foot to foot closest to the receiver when passing
- Fingers should finish pointing towards receiver upon completion of the pass

Receiving the Football Coaching Points

- Weight on foot closest to the passer
- Arms extended away from body with a slight bend at the elbows
- Hands up just above chest height for target (e.g. 'W' shape with thumbs and index fingers)
- Catch football off the chest
- DO NOT bring football back to the chest to pass.

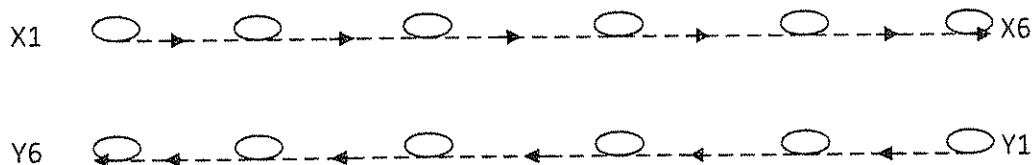

X1 Passes to X2 and so on down the line. Y1 to Y2 do the same, when the ball gets to the end reverse the procedure.

- Variation** -Time - How long it takes to complete either of the following:
- (a) 1 turn
 - (b) 6 balls down the line.
 - (c) Players to swerve between domes to top of line.

(2) COMBINATION PASSING

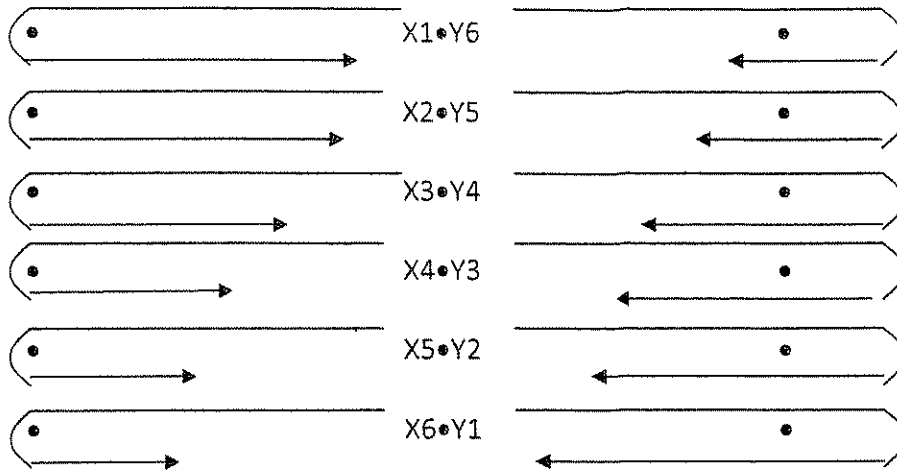

Two lines of players stand back to back. X1 and Y1 start with the footballs. The teams stand and pass along their own lines e.g. X1 to X6, Y1 to Y6. When the ball reaches players X6 & Y6 they hand the ball to players X1 & Y1 of the opposite team who then commences to run towards the markers that are ten meters in front of them performing a running pass with their team, i.e. Y1 to Y6 and X1 to X6. On reaching and turning around the markers complete a running pass on return before repeating the drill again.

(3) STAR DRILL

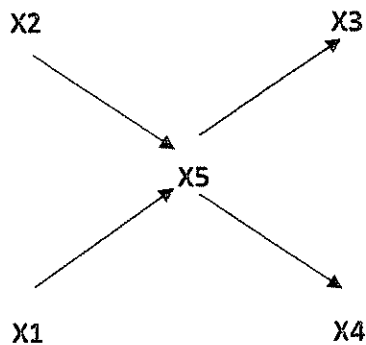

X5 stands in the middle of the square. X1 and X2 have 3 footballs beside them. X1 passes the football to X5 who must catch and pass the football to X3 who catches the ball and places it on the ground. X2 then passes the football to X5 who then passes to X4 who catches the football and places it on the ground. Once all footballs are with X3 and X4 the drill is repeated with X1 and X2 becoming the receivers. Rotate the middle person.

- Variation**
- Increase speed of the footballs coming to the person in the middle for less reaction time.
 - Use different shaped or sized balls.

(4) QUICK HANDS DRILL

Running Pass Coaching Points

- When starting drill all players should have outside foot up so first movement is forward e.g. If ball is starting on the right the left foot should be up - **Lead Foot**.
- Receive the ball early, no chesting the football.
- Feet Position i.e. passing off the foot furthest away from target.
- Shoulder and hip rotation.
- Arm action i.e. across body - or swept down towards knees.
- Fingers point to target area on release of the pass.

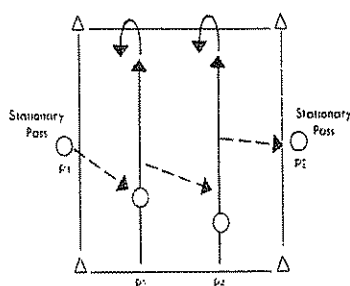

Set up three (3) markers along side of each other no more than a metre apart. Place another three (3) opposite the current three (3) hats 2 metres in front of them. A coach or player provides a standing pass to X1 who performs a running pass to X2 who has to tip it onto X3 who then passes to another coach or player on the other side. The 3 players move around their hats in front of them and perform the same drill on the way back receiving the ball from the other side. Once players perform the drill with competency increase the width and length of the drill.

(5) EXTENDED RUNNING PASS DRILL

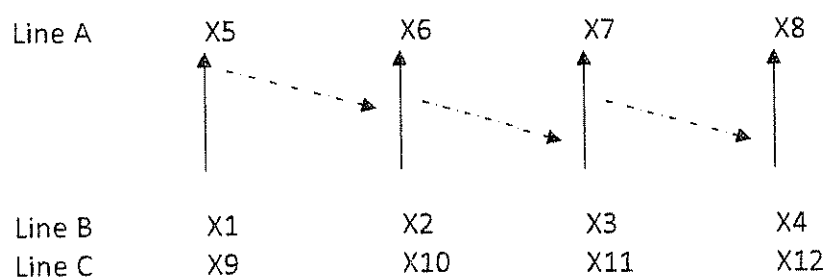

Line A runs towards Line B passing the ball along the line. When at Line B final receiver hands off to first player in that line. Line B returns to Line C. Drill repeats

Variations: Face ball and second man e.g. 1 to 3, 3 to 2, 2 to 4.

(6) SPEED RUNNING PASS DRILL

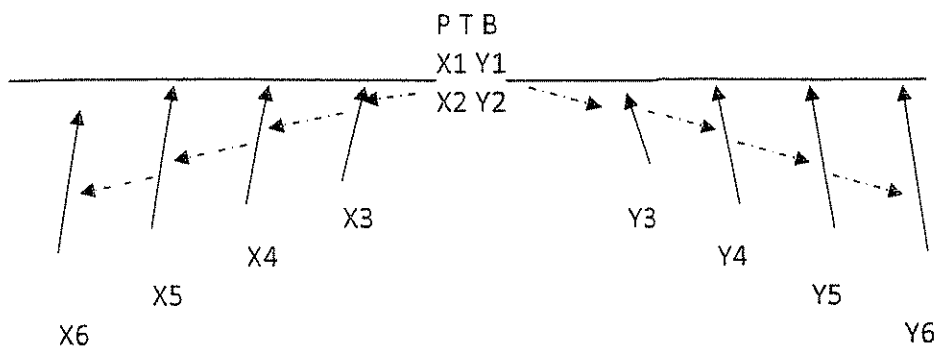

X1 and Y1 play the ball for their respective teams (commencing on the ground). The dummy half for each team (X2, Y2) passes to a running backline who must complete their passing to the outside man before reaching the advantage line. The outside player then runs across to the PTB and all players move one position e.g. X1 to X2, e.g. X2 to X3. The drill continues until all players have been in all positions (rotation of groups).

(7) L DRILL

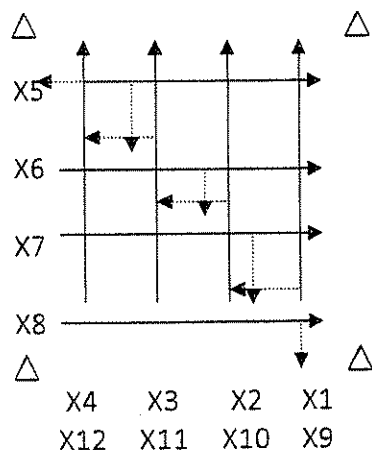

Set up 10m x 10m grid. Players set up in lines of four (4) in an L shape. The ball starts on the outside of the line with X1 who moves forward and performs a running pass to X2. X2 passes to X3 and on to X4. When X4 receives the ball he passes to X5. X5 runs forward and performs a running pass to X6. The ball progresses to X8 who then passes to X9 and the drill repeats. Once players are at the end of the grid they have to move quickly around to the other side of the grid ready to receive the ball to continue the drill.

Players must run straight and get to the end of the grid before they can move to the other side. Place markers at the top of each side for players struggling to stay straight while passing.

(8) FORM PASSING

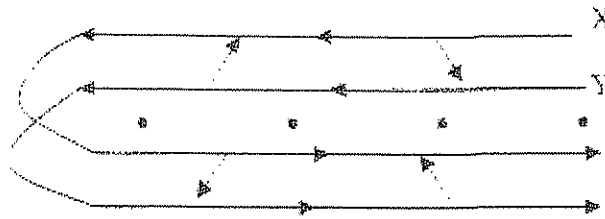

Players run through tunnel in pairs each passing off the outside foot. When they reach the end of the tunnel players return down the other side, if the player is the left player on the way down he is the right player on the way back thereby passing both left and right.

(9) Channel Passing

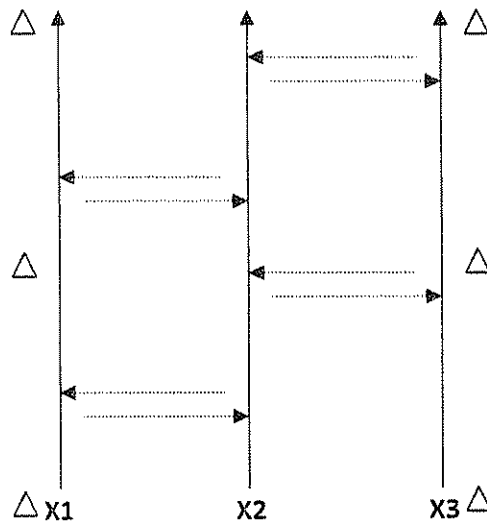

Players X1, X2 and X3 start evenly spaced in the channel. Players jog down the channel holding their width. X1 passes the football to X2 who catches and passes straight back to X1. X3 then passes the football to X2 with X2 catching and passing straight back to X3. This is a continuous running pass drill with X1 and X3 repeating their roles until the end of the grid.

- Variety**
- Outside players to pass as soon as middle player passes the football back to original passer.
 - Increase the width of the grid
 - Increase the speed

ESTABLISH THE CATCH, PASS IT PERFECT